



**2012–2013 Euro Price List  
Precision Farming Products**

A Subsidiary of  *Spraying Systems Co.*®

[www.TeeJet.com](http://www.TeeJet.com)



Aabybro Facility

Prices effective September 1, 2012

Prices are subject to change without notice and are subject to freight, duty and local taxes. All prices are ex. works Aabybro and payable in Euros. Terms and Conditions of sale are to be found on the final page of this document.

The Product class is determining the actual discount rate on the product.

Part numbers marked with '\*' = RTK

Part numbers marked with '\*\*' = REP

Part numbers marked with '\*\*\*' = WHE

Part numbers without mark = SAP

Please contact your regional office or TeeJet Technologies if you are in doubt about your actual discount rate.

# MATRIX<sup>®</sup> PRO AND ACCESSORIES

## SYSTEM DIAGRAM

### MATRIX<sup>®</sup> PRO

See pages 2 - 3

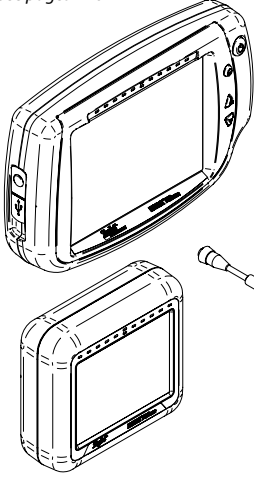

### Antennas & Receivers

RXA-30 GPS Antenna 90-02720  
 GPS Antenna 78-50155  
 GPS Antenna 78-50190 w/GLONASS  
 RX510 GPS Receiver 90-02703  
 RX610 GPS Receiver 90-02793  
 See page 10

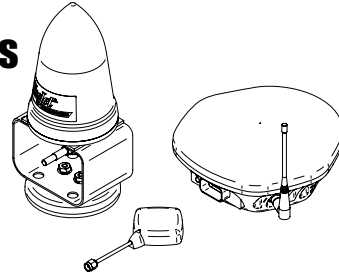

### RealView<sup>®</sup> Camera

Video Selector Module 78-08068: 8 Channel  
 Video Selector Module 78-08067: 4 Channel  
 RealView Camera 16-00022  
 Camera Extension Cable 45-05617: 20'/6m  
 Camera Extension Cable 45-05618: 60'/18m  
 See page 5

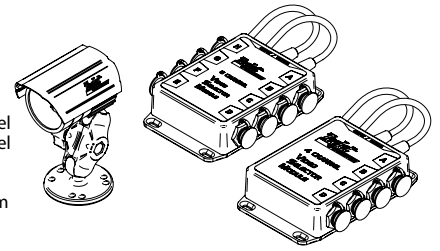

UniPilot Assisted Steering System 90-02806  
 Steering Control Module (SCM) 78-08075  
 SCM Harness 45-07708  
 Footswitch 32-04020  
 See page 9

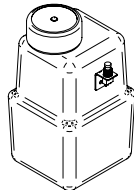

### Pressure to CAN

Pressure Interface Kit  
 90-04005: 10'/3m  
 90-04006: 32'/10m  
 See page 5

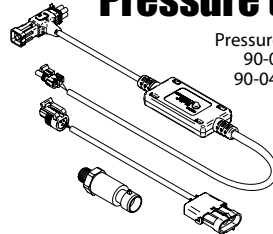

### BoomPilot<sup>®</sup>

BoomPilot Harness - Part number  
 dependent on Rate Controller & Sprayer Model  
 BoomPilot Section Driver Module 78-05077  
 See pages 6-8

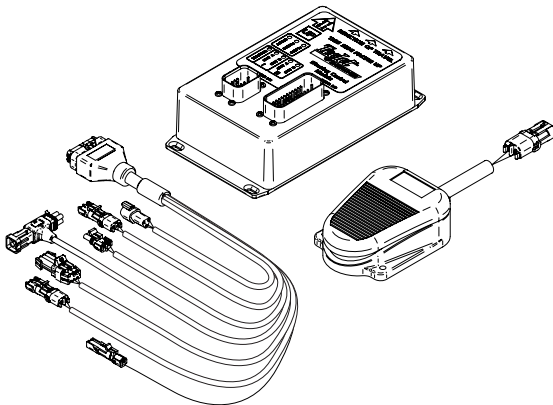
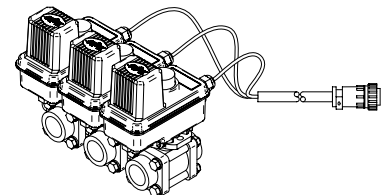
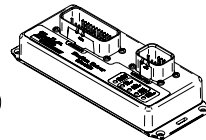
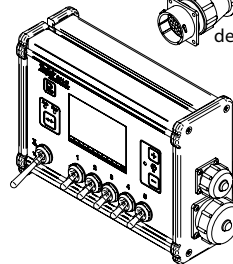

# MATRIX® PRO 570GS

	PART NO.	DESCRIPTION	EURO
<p>78-50155 GPS Antenna 78-50190 GPS Antenna w/GLONASS</p> <p>Matrix Pro 570GS 75-30094 75-30095 w/GLONASS</p> <p>90-02349 Kit, RAM Mount</p> <p>16-00022 RealView Camera</p> <p>45-05617: 20'/6 m 45-05618: 60'/18 m Camera Extension Cable</p> <p>5 Pos. 8 Pos.</p> <p>45-05625 COBO Power Cable</p>	<b>KITS</b>		
	90-02770-xx	Matrix Pro 570GS No Receiver; COBO .....	\$ 2295,00
	90-02771-xx	Matrix Pro 570GS No Receiver; RealView® Camera; COBO .....	2495,00
	90-02772-xx	Matrix Pro 570GS w/ClearPath; Patch Antenna; COBO .....	2595,00
	90-02768-xx	Matrix Pro 570GS w/ClearPath; Patch Antenna; RealView Camera; COBO .....	2795,00
	90-02773-xx	Matrix Pro 570GS w/ClearPath; RXA-30 Antenna; COBO .....	2795,00
	90-02774-xx	Matrix Pro 570GS w/ClearPath; RXA-30 Antenna; RealView Camera; COBO .....	2995,00
	90-02775-xx	Matrix Pro 570GS w/ClearPath/GLONASS; Patch Antenna; COBO .....	2795,00
	90-02769-xx	Matrix Pro 570GS w/ClearPath/GLONASS; Patch Antenna; RealView Camera; COBO .....	2995,00
	90-02776-xx	Matrix Pro 570GS w/ClearPath/GLONASS; RXA-30 Antenna; COBO .....	2995,00
90-02777-xx	Matrix Pro 570GS w/ClearPath/GLONASS; RXA-30 Antenna; RealView Camera; COBO .....	3195,00	
<b>CABLES</b>			
45-05624	Cable, Power, Lighter .....	59,44	
45-05625	Cable, Power, COBO .....	55,03	
45-05845	Cable, Power CAN, RS232 Adapter to Conxall 8PG .....	128,23	
See BoomPilot for other cable options For Matrix Pro GS Manual, See Page 4			

xx – CZ, DE, DK, ES, FR, FI, HU, IT, NL, PL, PT, RU, SV, UK, JA, ZH

# MATRIX® PRO 840GS

	PART NO.	DESCRIPTION	EURO
<p>78-50155 GPS Antenna 78-50190 GPS Antenna w/GLONASS</p> <p>Matrix Pro 840GS 75-30097 75-30098 w/GLONASS</p> <p>90-02700 Kit, RAM Mount</p> <p>16-00022 RealView Camera</p> <p>45-05617: 20'/6 m 45-05618: 60'/18 m Camera Extension Cable</p> <p>5 Pos. 8 Pos.</p> <p>45-05625 COBO Power Cable</p>	<b>KITS</b>		
	90-02779-xx	Matrix Pro 840GS No Receiver; COBO .....	\$ 3095,00
	90-02780-xx	Matrix Pro 840GS No Receiver; RealView Camera; COBO .....	3295,00
	90-02781-xx	Matrix Pro 840GS w/ClearPath; Patch Antenna; COBO .....	3395,00
	90-02782-xx	Matrix Pro 840GS w/ClearPath; Patch Antenna; RealView Camera; COBO .....	3595,00
	90-02783-xx	Matrix Pro 840GS w/ClearPath; RXA-30 Antenna; COBO .....	3595,00
	90-02784-xx	Matrix Pro 840GS w/ClearPath; RXA-30 Antenna; RealView Camera; COBO .....	3795,00
	90-02785-xx	Matrix Pro 840GS w/ClearPath/GLONASS; Patch Antenna; COBO .....	3595,00
	90-02786-xx	Matrix Pro 840GS w/ClearPath/GLONASS; Patch Antenna; RealView Camera; COBO .....	3795,00
	90-02787-xx	Matrix Pro 840GS w/ClearPath/GLONASS; RXA-30 Antenna; COBO .....	3795,00
90-02788-xx	Matrix Pro 840GS w/ClearPath/GLONASS; RXA-30 Antenna; RealView Camera; COBO .....	3995,00	
<b>CABLES</b>			
45-05624	Cable, Power, Lighter .....	59,44	
45-05625	Cable, Power, COBO .....	55,03	
45-05845	Cable, Power CAN, RS232 Adapter to Conxall 8 Pos. ....	128,23	
See BoomPilot for other cable options For Matrix Pro GS Manual, See Page 4			

xx – CZ, DE, DK, ES, FR, FI, HU, IT, NL, PL, PT, RU, SV, UK, JA, ZH

# MATRIX® PRO 570G

	PART NO.	DESCRIPTION	EURO	
<p>GPS Antenna 78-50155 78-50190 w/GLONASS</p> <p>Matrix Pro 570G 75-30082 w/ ClearPath 75-30083 w/ ClearPath &amp; GLONASS</p> <p>Kit, RAM Mount w/Suction Cup 90-02349</p> <p>RealView Camera 16-00022</p> <p>8 Pos. Switch Box Work On-Off Switch 78-00046</p> <p>5 Pos.</p> <p>8 Pos.</p> <p>8 Pos.</p> <p>Power Cable, COBO 45-05625</p> <p>Camera Extension Cable 45-05617: 6 m 45-05618: 18 m</p>	<b>KITS</b>			
	90-02608-xx	Matrix Pro 570G No Receiver; COBO .....	€ 1.695,00	
	90-02609-xx	Matrix Pro 570G No Receiver; RealView® Camera; COBO .....	1.895,00	
	90-02610-xx	Matrix Pro 570G w/ClearPath; Patch Antenna; COBO.....	1.995,00	
	90-02555-xx	Matrix Pro 570G w/ClearPath; Patch Antenna; RealView Camera; COBO .....	2.195,00	
	90-02611-xx	Matrix Pro 570G w/ClearPath; RXA-30 Antenna; COBO.....	2.195,00	
	90-02612-xx	Matrix Pro 570G w/ClearPath; RXA-30 Antenna; RealView Camera; COBO .....	2.395,00	
	90-02613-xx	Matrix Pro 570G w/ClearPath/GLONASS; Patch Antenna; COBO	2.195,00	
	90-02557-xx	Matrix Pro 570G w/ClearPath/GLONASS; Patch Antenna; RealView Camera; COBO .....	2.395,00	
	90-02614-xx	Matrix Pro 570G w/ClearPath/GLONASS; RXA-30 Antenna; COBO.....	2.395,00	
	90-02615-xx	Matrix Pro 570G w/ClearPath/GLONASS; RXA-30 Antenna; RealView Camera; COBO .....	2.595,00	
	<b>CABLES</b>			
	45-05624	Cable, Power, Lighter.....	59,44	
	45-05625	Cable, Power, COBO .....	55,03	
45-05845	Cable, Power CAN, RS232 Adapter to Conxall 8PG .....	128,23		
<i>See BoomPilot for other cable options</i>				
xx – CZ, DE, DK, ES, FR, FI, HU, IT, NL, PL, PT, RU, SV, UK, JA, ZH				

# MATRIX® PRO 840G

	PART NO.	DESCRIPTION	EURO	
<p>GPS Antenna 78-50155 78-50190 w/GLONASS</p> <p>Matrix Pro 840G 75-30084 w/ ClearPath 75-30090 w/ ClearPath &amp; GLONASS</p> <p>Kit, RAM Mount w/Suction Cup 90-02700</p> <p>RealView Camera 16-00022</p> <p>8 Pos. Switch Box Work On-Off Switch 78-00046</p> <p>5 Pos.</p> <p>8 Pos.</p> <p>8 Pos.</p> <p>Power Cable, COBO 45-05625</p> <p>Camera Extension Cable 45-05617: 6 m 45-05618: 18 m</p>	<b>KITS</b>			
	90-02633-xx	Matrix Pro 840G No Receiver; COBO .....	€ 2.495,00	
	90-02634-xx	Matrix Pro 840G No Receiver; RealView Camera; COBO .....	2.695,00	
	90-02635-xx	Matrix Pro 840G w/ClearPath; Patch Antenna; COBO.....	2.795,00	
	90-02636-xx	Matrix Pro 840G w/ClearPath; Patch Antenna; RealView Camera; COBO .....	2.995,00	
	90-02637-xx	Matrix Pro 840G w/ClearPath; RXA-30 Antenna; COBO.....	2.995,00	
	90-02638-xx	Matrix Pro 840G w/ClearPath; RXA-30 Antenna; RealView Camera; COBO .....	3.195,00	
	90-02639-xx	Matrix Pro 840G w/ClearPath/GLONASS; Patch Antenna; COBO	2.995,00	
	90-02640-xx	Matrix Pro 840G w/ClearPath/GLONASS; Patch Antenna; RealView Camera; COBO .....	3.195,00	
	90-02641-xx	Matrix Pro 840G w/ClearPath/GLONASS; RXA-30 Antenna; COBO.....	3.195,00	
	90-02642-xx	Matrix Pro 840G w/ClearPath/GLONASS; RXA-30 Antenna; RealView Camera; COBO .....	3.395,00	
	<b>CABLES</b>			
	45-05624	Cable, Power, Lighter.....	59,44	
	45-05625	Cable, Power, Direct to Battery, 10'/3 m .....	55,03	
45-05845	Cable, Power CAN, RS232 Adapter to Conxall 8PG .....	128,23		
<i>See BoomPilot for other cable options</i>				
xx – CZ, DE, DK, ES, FR, FI, HU, IT, NL, PL, PT, RU, SV, UK, JA, ZH				

# MATRIX<sup>®</sup> PRO REFERENCE MATERIAL

	PART NO.	DESCRIPTION	EURO
	98-05239	Matrix Pro User Manual, UK, English .....	€ 22,47
	98-01381	Matrix Pro Quick Start Up Guide, UK, English .....	12,77
	98-01382	Matrix Pro Quick Start Up Guide, ZH, Chinese .....	12,77
	98-01383	Matrix Pro Quick Start Up Guide, CS, Czech. ....	12,77
	98-01384	Matrix Pro Quick Start Up Guide, DA, Danish .....	12,77
	98-01385	Matrix Pro Quick Start Up Guide, NL, Dutch .....	12,77
	98-01386	Matrix Pro Quick Start Up Guide, FI, Finnish .....	12,77
	98-01387	Matrix Pro Quick Start Up Guide, FR, French .....	12,77
	98-01388	Matrix Pro Quick Start Up Guide, DE, German .....	12,77
	98-01389	Matrix Pro Quick Start Up Guide, HI, Hindi. ....	12,77
	98-01390	Matrix Pro Quick Start Up Guide, HU, Hungarian. ....	12,77
	98-01391	Matrix Pro Quick Start Up Guide, IT, Italian .....	12,77
	98-01392	Matrix Pro Quick Start Up Guide, JA, Japanese. ....	12,77
	98-01393	Matrix Pro Quick Start Up Guide, PL, Polish. ....	12,77
	98-01395	Matrix Pro Quick Start Up Guide, PT, Portuguese .....	12,77
	98-01396	Matrix Pro Quick Start Up Guide, RU, Russian. ....	12,77
	98-01398	Matrix Pro Quick Start Up Guide, ES, Spanish .....	12,77
	98-01399	Matrix Pro Quick Start Up Guide, SV, Swedish .....	12,77
	98-01438	Matrix Pro Quick Start Up Guide, RO, Romanian .....	12,77
	98-01439	Matrix Pro Quick Start Up Guide, SR, Serbian .....	12,77
	98-01440	Matrix Pro Quick Start Up Guide, ET, Estonian .....	12,77
	98-05273	Matrix Pro GS User Manual, UK, English .....	22,47
	98-05285	Matrix Pro GS User Manual, DA, Danish .....	22,47
	98-05295	Matrix Pro GS User Manual, NL, Dutch. ....	22,47
	98-05290	Matrix Pro GS User Manual, FR, French .....	22,47
	98-05286	Matrix Pro GS User Manual, DE, German. ....	22,47
	98-05293	Matrix Pro GS User Manual, IT, Italian. ....	22,47
	98-05296	Matrix Pro GS User Manual, PL, Polish .....	22,47
	98-05297	Matrix Pro GS User Manual, PT, Portuguese. ....	22,47
	98-05299	Matrix Pro GS User Manual, RU, Russian .....	22,47
	98-05287	Matrix Pro GS User Manual, ES, Spanish .....	22,47

# MATRIX® PRO ACCESSORIES

	PART NO.	DESCRIPTION	EURO
	<b>CAMERA</b>		
	90-02546	Kit, RealView® Camera, with Mount and 6 m Cable .....	€ 330,20
	90-02565	Kit, Video Selector with 4 Cameras & 6 m Extension .....	1628,97
	78-08067	Video Selector Module, 4 Channel Video MUX .....	440,26
	78-08068	Video Selector Module, 8 Channel Video MUX .....	522,81
	<b>MOUNTING</b>		
	90-02349	Kit, RAM Mount with Suction Cup .....	100,24
	90-02700	Kit, RAM Mount, Matrix Pro 840, with 4.5" Suction Cup .....	104,11
	78-50179	Magnetic Mount for Camera. ....	38,52
	65-05179	Plate, Mounting for Patch Antenna .....	7,86
	65-05185	RAM Mount for Camera .....	38,52
	90-02725	Suction Cup Upgrade for Matrix Pro 570G and CenterLine 220. ....	106,86
	<b>ANTENNA</b>		
	78-50155	Antenna, GPS Patch II, 5 m. ....	150,95
	78-50190	Antenna, GPS Patch L1 with GLONASS .....	192,35
	90-02720	Kit, RXA-30 Antenna with 6 m Cable .....	439,16
	90-02721	Kit, RXA-30 Antenna with 9 m Cable .....	456,77
	<b>CABLES</b>		
	45-05617	Cable, Camera Extension, 6 m .....	104,56
	45-05618	Cable, Camera Extension, 18 m .....	137,58
	45-05624	Cable, Power, Matrix - EU Lighter Plug .....	59,44
	45-05625	Cable, Power, Matrix - COBO .....	55,03
	45-05775	Cable, Power, Matrix - Battery, 3 m .....	71,28
	45-05826	Cable, Power, CAN, Conxall 8PG to COBO, 3.6 m .....	138,92
	45-05845	Cable, Power, CAN, Conxall 8PG to Packard, 2.85 m .....	128,23
	45-05647	Cable, Power, Packard - EU Lighter Plug .....	61,35
	198-601	Cable, Power, Packard - Battery .....	79,01
	45-05648	Cable, Power, Packard - COBO .....	55,42
	45-05676	Cable, GPS Antenna Extension for Patch or RXA-30, 7.5 m. ....	174,01
	45-08101	CAN Termination Male 4 Pos. WP .....	8,15
	90-02472	Kit, Patch Antenna extension cable, 3 m. ....	120,29
	90-04005	Kit, DSM Pressure Interface, 10'3 m. ....	599,00
	90-04006	Kit, DSM Pressure Interface, 32'10 m .....	629,00
	198-555	Cable, Open End, 2 WSire, 10 m, 2 Pos. Super Seal .....	34,34
	166-255	8A fuse for 45-05647 .....	4,44
	166-403	3A fuse for 45-05648 .....	5,18
	198-513	Cable, Speed Out to Bogballe. ....	142,23
	198-514	Cable, Speed Out to LH500/LH85 .....	97,35
	198-593	Cable, Speed Out to JST F/junct .....	67,84
	198-669	Cable, Speed Out to TJ844. ....	72,12
	198-675	Cable, Speed Out to TJ860. ....	68,53
	198-677	Cable, Speed Out to TJ70 .....	47,78
	198-686	Cable, Speed Out to TJ500 & Müller Contr., 8 Pos. Connection. .	97,35
	198-687	Cable, Speed Out to Amatron + & Müller Spraydos .....	93,41
	198-688	Cable, Speed Out to Sulky Vision. ....	133,25
	<b>MISCELLANEOUS</b>		
	90-02757	Kit, Tilt Gyro Module Pro. ....	897,01
	78-00046	Switch, Work On-Off, 8 Pos. Connector .....	104,56
	<i>See BoomPilot for other cable options</i>		

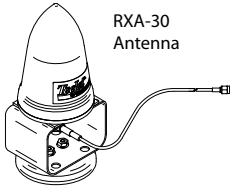

RXA-30 Antenna



GPS Patch II Antenna

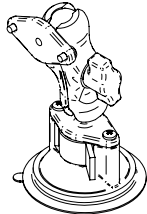

RAM Mount w/ Suction Cup

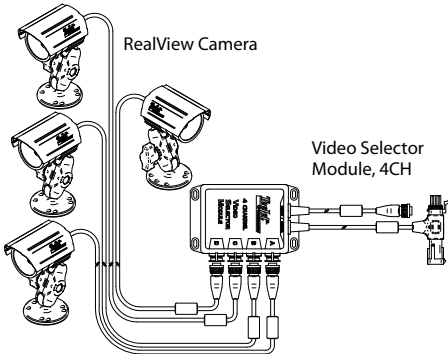

RealView Camera

Video Selector Module, 4CH

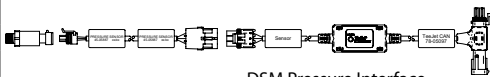

DSM Pressure Interface  
90-04005 10'3 m  
90-04006 32'10 m

# BoomPilot® SPRAYER KITS

SPRAYER CONTROLLER	IMPLEMENT MANUFACTURER	DESCRIPTION	MATRIX PART NUMBERS	EURO PRICE	SMART CABLE	SDM	JUNCTION BOX	CANBUS	INSTALLATION
TJ744E		5 Sections	198-396 .... 78-05072 ... 45-05845 ...	224,53 729,74 128,23		x			Easy
TJ834/844/854 based computers		1 - 9 Sections + Master	198-410 .... 78-05072 ... 45-05845 ...	228,85 729,74 128,23		x			Easy
TJ844		1 - 13 Sections + Master	198-415 .... 78-05072 ... 45-05845 ...	252,62 729,74 128,23		x			Easy
EL4	John Deere	1 - 9 Sections + Master	198-398 .... 78-05072 ... 45-05845 ...	224,53 729,74 128,23		x			Easy
Hardi HC2500 w/ ScanBox	Hardi	7 Sections	903-319 .... 45-05845 ...	1205,22 128,23			x		Easy
Hardi HC5500	Hardi	All	78-05096 ... 45-05826 ... 45-08101 ...	544,99 138,92 8,15	x				Easy
ARAG 466 Switch Box		5 Sections + Master	903-336 .... 45-05845 ...	1095,15 128,23			x		Easy
Müller Spray Control S (Standard version only)		Max. 9 Sections + Master	903-322 .... 45-05845 ...	1535,42 128,23			x		Medium
LH4000/5000 w/ standard BT-9		3 - 9 Sections + Master	903-339 .... 45-05845 ...	1755,55 128,23			x		Medium
Blanchard REB1	Blanchard	Max. 9 Sections + Master	903-335 .... 45-05845 ...	1535,42 128,23			x		Medium
Kuhn / Blanchard REB3 (ver. 8.03-3)	Kuhn / Blanchard	Max. 11 Sections + Master Includes Optima Interface	990-906 .... 45-05845 ...	2835,35 128,23		x			Medium
Kuhn / Blanchard REB3 (ver. 8.03-3)	Kuhn / Blanchard	Max. 11 Sections + Master Excludes Optima Interface	990-907 .... 45-05845 ...	1400,38 128,23		x			Medium
DUBEX (Müller Spray Control S)	Dubex	1 - 11 Sections + Master	903-338 .... 45-05845 ...	1810,58 128,23			x		Medium
Berthoud DP Tronic ≥ 2011 (Factory installed interface)	Berthoud	Max. 15 Sections + Master for New Safi or Pneumatic Valves	990-888 .... 45-05845 ...	1054,11 128,23		x			Medium
Berthoud DP Tronic ≥ 2011 (Factory installed interface)	Berthoud	Max. 15 Sections + Master Old Safi or ARAG Valves	990-889 .... 45-05845 ...	1476,77 128,23		x			Medium
Berthoud DP Tronic ≤ 2010	Berthoud	Max. 15 Sections + Master for New Safi or Pneumatic Valves	990-888 .... 45-05845 ... 902-422 ....	1054,11 128,23 531,66		x			Advanced
Berthoud DP Tronic ≤ 2010	Berthoud	Max. 15 Sections + Master Old Safi or ARAG Valves	990-889 .... 45-05845 ... 902-422 ....	1476,77 128,23 531,66		x			Advanced
Müller SprayDos		5 Sections + Master Only Müller standard version with "Low profile connector"	903-326 .... 45-05845 ...	1535,42 128,23			x		Advanced
Müller SprayDos		7 Sections + Master Only Müller standard version with "Low profile connector"	903-325 .... 45-05845 ...	1535,42 128,23			x		Advanced
Müller SprayDos		9 Sections + Master Only Müller standard version with "Low profile connector"	903-327 .... 45-05845 ...	1535,42 128,23			x		Advanced
ARAG BRAVO 300		5 Sections + Master	903-333 .... 45-05845 ...	1535,42 128,23			x		Advanced
ARAG BRAVO 180		4 Sections + Master	903-330 .... 45-05845 ...	1535,42 128,23			x		Advanced
ARAG BRAVO 180		5 Sections + Master	903-331 .... 45-05845 ...	1535,42 128,23			x		Advanced

For other types of controllers please contact TeeJet Technologies



# TJ844 BOOMPILOT

## SYSTEM DIAGRAM

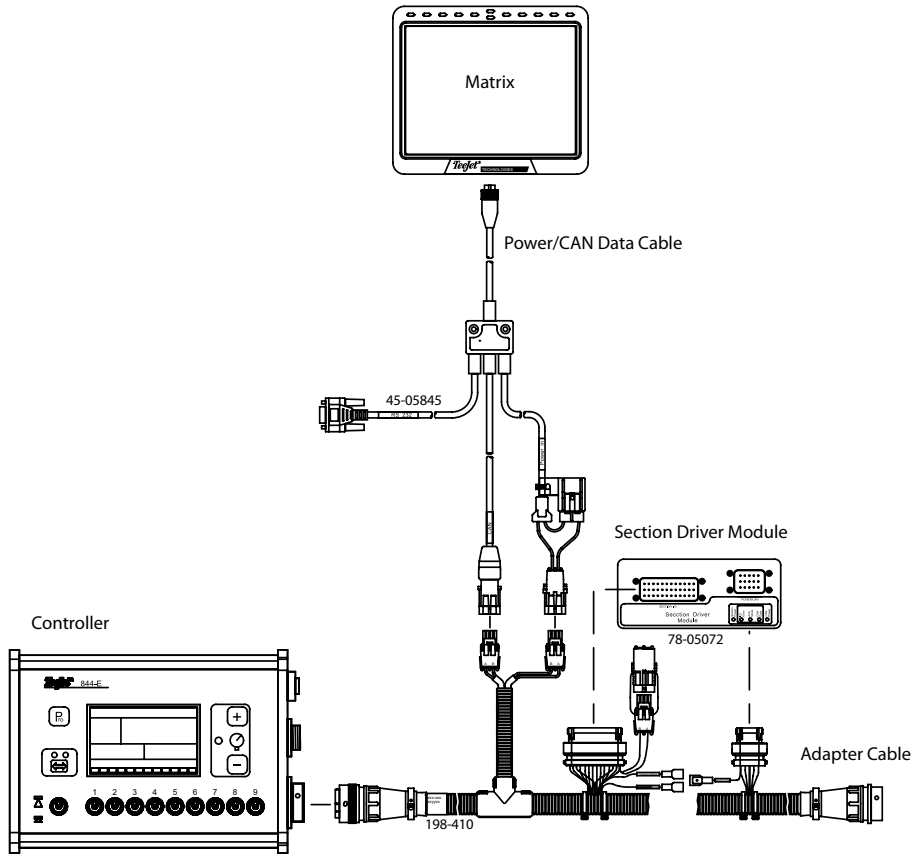

# MÜLLER SPRAY CONTROL BOOMPILOT

## SYSTEM DIAGRAM

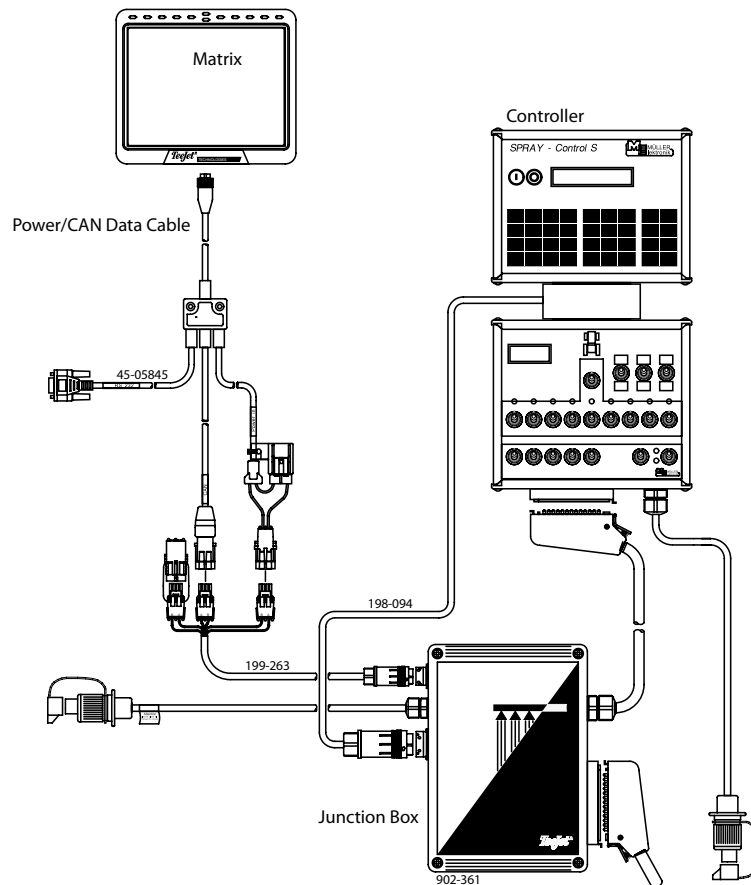

# BoomPilot® SPREADER KITS

SPRAYER CONTROLLER	IMPLEMENT MANUFACTURER	DESCRIPTION	MATRIX PART NUMBERS	EURO PRICE	SMART CABLE	SDM	JUNCTION BOX	CANBUS	INSTALLATION
CALIBRATOR ZURF (ver. 1.12)	Bogballe	8 Virtual Sections	78-05082 45-05826 45-08101	544,99 138,92 8,15	x				Easy
CALIBRATOR UNIQ (ver. 1.12) (HW 361 and 362)	Bogballe	8 Virtual Sections	78-05082 45-05826 45-08101	544,99 138,92 8,15	x				Easy
CALIBRATOR ICON (From ver. 1.12)	Bogballe	8 Virtual Sections	78-05082 45-05826 45-08101	544,99 138,92 8,15	x				Easy
TJ500 Bredal (from ver. 1.02)	Bredal	Advanced, Virtual Sections	198-471 45-05826	91,38 138,92				x	Easy
TJ500 Bredal (from ver. 1.02)	Bredal	Basic, Virtual Sections Note: Not possible to connect VSM, SCM, TGM etc.	198-461	145,06				x	Easy
TJ500 MuA (from ver. 2.04)	MuA	Advanced, Virtual Sections	198-471 45-05826	91,38 138,92				x	Easy
TJ500 MuA (from ver. 2.04)	MuA	Basic, Virtual Sections Note: Not possible to connect VSM, SCM, TGM etc.	198-461	145,06				x	Easy
Quantron E (From ver. 3.50.00)	Rauch		78-05090 45-08101 45-05826 197-885	544,99 8,15 138,92 201,95	x				Medium
Quantron E2 (From ver. 1.20.00)	Rauch		78-05090 45-08101 45-05826 197-885	544,99 8,15 138,92 201,95	x				Medium
Quantron P (Axera H EMC) (From ver. 3.10)	Rauch	Virtual Sections Note: Not possible to connect VSM, SCM, TGM etc.	198-462	253,26				x	Medium

For other types of controllers please contact TeeJet Technologies

## BOGBALLE CALIBRATOR BOOMPILOT SYSTEM

SYSTEM DIAGRAM

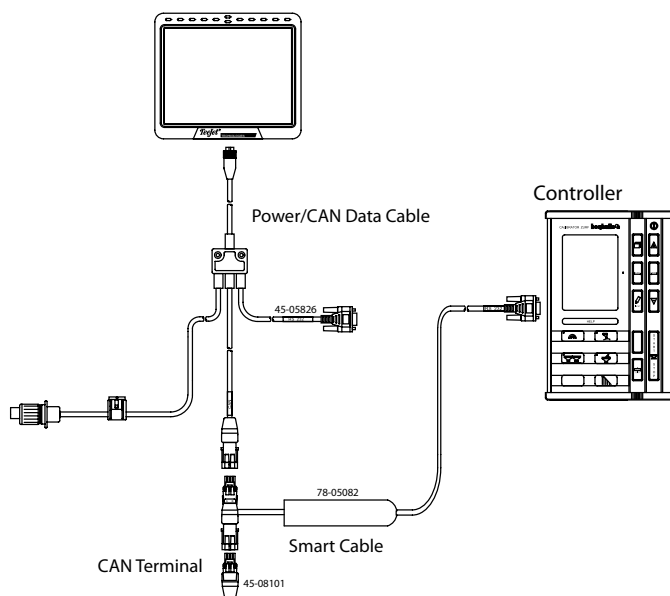

## RAUCH QUANTRON-P BOOMPILOT SYSTEM

SYSTEM DIAGRAM

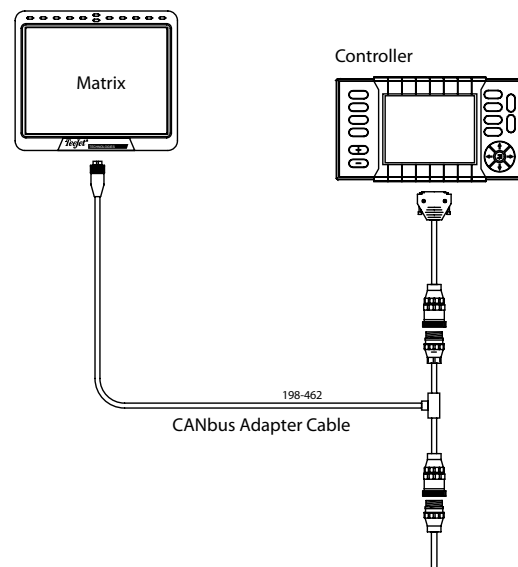

# UNIPILOT<sup>®</sup> FOR MATRIX<sup>®</sup> PRO

	PART NO.	DESCRIPTION	EURO
<p>to Matrix Guidance product</p> <p>45-05626 Power/CAN/Data Cable</p> <p>45-07727 SCM Power In/Out</p> <p>78-08075 Steering Control Module (SCM)</p> <p>45-07718 SCM Harness</p> <p>45-08101 CAN Terminator</p> <p>32-04057 System Ready Switch</p> <p>90-02806 UniPilot Assisted Steering System</p> <p>32-04040 Remote Engage/Disengage Switch</p> <p>32-04020 Optional Footswitch</p> <p>45-05381 Battery 12' w/15Amp Fuses</p>	<b>KITS</b>		
	91-02400	Kit, UniPilot System with SCM, ESM, and Mounting Bracket (Matrix not included) .....	€ 4413,13
	91-02402	Kit, UniPilot System with SCM, ESM, and Mounting Bracket (Matrix and Power/CAN/Data cable not included) .....	4300,09
	90-02806	Kit, UniPilot ESM and Brackets only .....	3543,11
		<b>UNIPILOT SYSTEM OPTIONS</b>	
	28-01030	Friction Wheel, Electric Steering Motor .....	41,45
	91-07015	Kit, Universal Mounting Brackets, UniPilot .....	308,73

# GPS RECEIVERS & ACCESSORIES

	PART NO.	DESCRIPTION	EURO	
<b>KITS</b>				
	90-02472	Kit, Patch Antenna Extension 3 m .....	€ 120,29	
	90-02473	Kit, Patch Antenna Extension 2 m .....	96,46	
	90-02720	Kit, RXA-30 Antenna with 6 m Cable .....	439,16	
	90-02721	Kit, RXA-30 Antenna with 9 m Cable .....	456,77	
	90-02703*	Kit, RX510 GPS Receiver with GLONASS/ClearPath, XP, HP. ....	5693,50	
	90-02793*	Kit, RX610 GPS Receiver, RTK, GPRS, HSPA, EU .....	8142,94	
	<b>COMPONENTS</b>			
	78-50155	Antenna, GPS Patch II with 5 m Cable .....	150,95	
	78-50190	Antenna, GPS Patch L1 with GLONASS .....	192,35	
	78-50148	Receiver, GPS RX370p, WAAS/EGNOS .....	2147,41	
<b>CABLES/MISCELLANEOUS</b>				
45-05676	Cable, GPS Antenna Extension, 7.5 m .....	174,01		
45-05786	Cable, RXA-30 Antenna, 6 m .....	122,21		
45-05787	Cable, RXA-30 Antenna, 9 m .....	193,76		
45-05340	Cable, RX370p Data (Port B) and Power .....	145,04		
45-05350	Cable, RX370p Data (Ports A & B) and Power .....	206,37		
45-05850	Cable, RX510/RX610, Dual Serial, Com 1 Matrix, Com 2 Serial SKTS. ....	233,44		
45-05808	Cable, Smart Antenna, Power Serial with Pins .....	138,71		
90-02744*	Quick Mounting Plate, RX510/RX610. ....	427,44		
90-02748	Plate, Mounting Kit for Patch Antenna .....	19,23		

\* Subject to RTK Discount

# GYRO & TILT CORRECTION

	PART NO.	DESCRIPTION	EURO	
<b>KITS</b>				
	90-02536	Kit, Tilt Gyro Module for Matrix® Including CAN Terminal. ....	€ 897,01	
	90-02757	Kit, Tilt Gyro Module for Matrix Pro Including CAN Terminal ...	897,01	
	91-00022	Kit, Articulated Gyro with Harness with 6 m Extension Cable, Matrix® Pro .....	881,60	
	<b>CABLES/MISCELLANEOUS</b>			
	45-05845	Cable, Power CAN, RS232 Adapter to Conxall 8 Plug .....	128,23	
	45-08112	Cable, CAN Extension 4 m .....	93,15	
	45-07716	Harness, Tilt Gyro Module CAN Tee. ....	117,33	
	78-08057	Module, Tilt Gyro. ....	587,73	
	78-08077	Module, Tilt Gyro Pro .....	587,73	
	78-08076	Module, Articulated Gyro, Matrix Pro. ....	587,73	









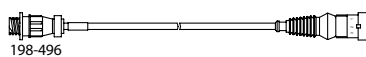
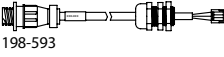

# CenterLine<sup>®</sup> 220

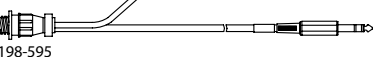
	PART NO.	DESCRIPTION	EURO
<p>GPS Patch Antenna 78-50155</p> <p>Console, CL220 75-30031 Console, Metric 75-30033 Console, Autonomous Metric 75-30034</p> <p>Kit, RAM Mount with Suction Cup (optional) 90-02349</p> <p>Metal Mounting Plate 65-05179</p> <p>GPS Speed Output</p> <p>Cable, COBO 45-05650</p> <p>Cable, Battery Power 45-05478</p> <p>Cable, Adapter 45-05471</p> <p>Cable, Lighter Adapter 45-05458</p>	<b>KITS/ANTENNA</b>		
	90-02349	Kit, RAM Mount with Suction Cup .....	€ 100,24
	90-02402-xx	Kit, CenterLine 220, Metric EGNOS .....	1065,84
	90-02552-yy	Kit, CenterLine 220, Autonomous Metric, EU .....	1065,84
	90-02662-xx	Kit, CenterLine 220, Metric EGNOS w/ RXA-30 Antenna .....	1333,64
	90-02472	Kit, Patch Antenna Extension 3 m .....	120,29
	90-02473	Kit, Patch Antenna Extension 2 m .....	96,46
	78-50155	Antenna, GPS Patch II with Cable, 4 m .....	150,95
	90-02720	Kit, RXA-30 Antenna w/ 6 m Cable .....	439,16
	90-02721	Kit, RXA-30 Antenna w/ 9 m Cable .....	456,77
	65-05179	Metal Mounting Plate (also requires 3 Velcro™ strips – #60-10081) .....	7,86
	<b>CONSOLES &amp; CABLES</b>		
	75-30034	Console, CenterLine 220 Autonomous Metric EU .....	948,01
	75-30032	Console, CenterLine 220, Metric EGNOS .....	948,01
	45-05458	Cable, CenterLine 220, Lighter Adapter .....	67,21
45-05459	Cable, CenterLine 220, GPS Simulator .....	84,90	
45-05476	Cable, CenterLine 220, GPS Data Programming Rev 1 .....	108,49	
45-05478	Cable, CenterLine 220, Battery Power .....	84,90	
45-05650	Cable, Power Assembly, CenterLine 220 COBO .....	60,66	
45-20042	Cable, 844 to DJ .....	55,53	

## TeeJet<sup>®</sup> TECHNOLOGIES SPEED SENSORS

	PART NO.	DESCRIPTION	EURO
<p>90-02371</p>	<b>GPS SPEED SENSORS</b>		
	90-02371-xx	GPS Speed Sensor with 4P AMP CPC Connector .....	€ 487,04
	90-02386-xx	GPS Speed Sensor with 3P Deutsch Connector. ....	487,04

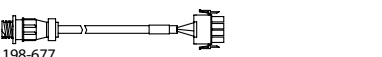
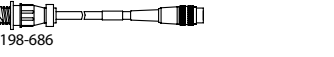
# GPS SPEED ADAPTER CABLES

	PART NO.	DESCRIPTION	EURO
	198-496	CenterLine® 220 and GPS Speed Sensor - Adapter Cable to TeeJet® Direct Cables (3P Amp Super Seal Connector).....	€ 106,18
	198-593	CenterLine 220 and GPS Speed Sensor - Adapter Cable to TeeJet Sprayer Junction Box (3P JST Connector).....	67,84
	198-595	CenterLine 220 and GPS Speed Sensor - Adapter Cable to Bogballe Calibrator Controller (Jack Connector).....	142,23
	198-669	CenterLine 220 and GPS Speed Sensor - Adapter Cable to TeeJet 844 Controller (7P Binder Connector - Male Pin).....	72,12
	198-670	CenterLine 220 and GPS Speed Sensor - Adapter Cable to LH500 And TeeJet-85 Controller (7P Binder Connector - Female Pin).....	105,97
	198-675	CenterLine 220 and GPS Speed Sensor - Adapter Cable to Framatome Pins (TeeJet-860).....	68,53
	198-677	CenterLine 220 and GPS Speed Sensor - Adaptor Cable to 70 Series Controller.....	47,78
	198-686	CenterLine 220 and GPS Speed Sensor, Adapter Cable to TeeJet-500 or Müller Terminal (8P Binder Connector).....	97,35
	198-687	CenterLine 220 And GPS Speed Sensor - Adapter Cable to Amazone Amatron+ (3P Binder Connector).....	93,41
	198-688	CenterLine 220 And GPS Speed Sensor, Adapter Cable to Sully Vision.....	133,25
	198-513	Matrix - Adapter Cable to Bogballe Calibrator Controller.....	142,23
	198-514	Matrix - Adapter Cable to LH500 And TeeJet-85 Controller (7P Binder Connector - Female Pin).....	97,35

## FEATURES

Uses a GPS receiver to measure true ground speed and delivers a frequency signal compatible with the radar signal speed input on most controls and monitors. GPS eliminates the problems frequently found with RADAR speed sensors from wet surfaces, moving crops or vehicle vibration.

Wide range of adapter cables to make it compatible with all popular application systems.

GPS speed sensor

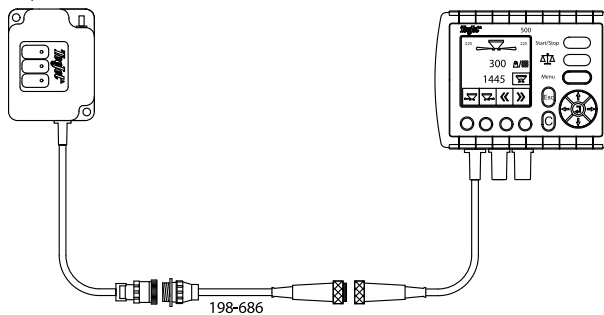

	PART NO.	DESCRIPTION	EURO
<b>KITS</b>			
<p>75-50060</p> <p>75-50061</p> <p>64-50023</p> <p>45-05789</p> <p>45-10133      45-10134</p>	990-040	TeeJet 744E-3 Kit, with 433EC (3-Section) Manifold, without Fittings.....	€ 1293,01
	990-041	TeeJet 744E-5 Kit, with 435EC (5-Section) Manifold, without Fittings.....	1506,73
	90-50249	TeeJet 744E-3 Kit, 100 PSI/7 Bar, without Manifold.....	550,19
	90-50250	TeeJet 744E-5 Kit, 100 PSI/7 Bar, without Manifold.....	845,01
	23800A-1/4	Isolator Kit 1/4" for Gauge.....	104,89
<b>ACCESSORIES</b>			
	75-50060	TeeJet 744E-3 Console, 100PSI/7 Bar.....	193,61
	75-50061	TeeJet 744E-5 Console, 100PSI/7 Bar.....	223,97
	45-05789	TeeJet 744E Power Cable, COBO, 1 m.....	63,00
	45-10133	TeeJet 744E, 3x430 Harness, 5.5 m.....	233,45
	45-10134	TeeJet 744E, 5x430 Harness, 5.5 m.....	265,56
	64-50023	Bracket F/744.....	19,99
	58580-1-433	430EC Manifold, 3-Section 3-Way 430 Valves	
	EC-3 ***	Square Bolt Adapter.....	746,26
	58580-1-435	430EC Manifold, 5-Section 3-Way 430 Valves	
	EC-3 ***	Square Bolt Adapter.....	1259,95
	98504-1-344	Regulation manifold 344 Regulating/Bypass,	
	BRL ***	80 Mesh Strainer, 98510-PP Pressure Valve.....	440,24
	58456-1/4 ***	1/4" NPT QCL Inlet Kit.....	15,90
	45529-P ***	Quick-Connect Plug.....	8,60
	AB98499-KIT ***	430 Mounting Kit (4 Bolt + O-ring).....	6,48
<b>Choose one inlet fitting:</b>			
	B58456-3/4 ***	3/4" BSBT Thread.....	15,90
	B58456-1 ***	1" BSBT Thread.....	15,90
	B58456-1-1/4 ***	1 1/4" BSBT Thread.....	15,90
	B58456-1-1/2 ***	1 1/2" BSBT Thread.....	15,90
	58456-1000 ***	1" Hose Barb.....	15,90
	58456-1250 ***	1 1/4" Hose Barb.....	15,90
	58456-1500 ***	1 1/2" Hose Barb.....	15,90
	58456-2000 ***	2" hose barb.....	15,90
<b>Choose three outlet fittings</b> <i>(Regulating Valve, 3-way valves and safety relief valve):</i>			
	45529-1/2 ***	1/2" Hose Barb Straight.....	8,60
	45529-3/4 ***	3/4" Hose Barb Straight.....	8,60
	45529-1 ***	1" Hose Barb Straight.....	8,60
	45529-90-1/2 ***	1/2" Hose Barb Angle.....	8,60
	45529-90-3/4 ***	3/4" Hose Barb Angle.....	8,60
	45529-90-1 ***	1" Hose Barb Angle.....	8,60
<b>Choose Three Fittings for TJ744E 3-Section, or Five for TJ744E 5-Section:</b>			
	45529-1/2 ***	1/2" Hose Barb Straight.....	8,60
	45529-3/4 ***	3/4" Hose Barb Straight.....	8,60
	45529-1 ***	1" Hose Barb Straight.....	8,60
	45529-90-1/2 ***	1/2" Hose Barb Angle.....	8,60
	45529-90-3/4 ***	3/4" Hose Barb Angle.....	8,60
	45529-90-1 ***	1" Hose Barb Angle.....	8,60
<b>FEATURES</b>			
	990-040:	Complete kit includes switch box for 3 sections, cables and 430 Manifold. No fittings included (Select from the above list).	
	990-041:	Complete kit includes switch box for 5 sections, cables and 430 Manifold. No fittings included (Select from the above list).	

For more details see the TeeJet Catalog 51

\*\*\* Subject to WHE Discount

	PART NO.	DESCRIPTION	EURO
<b>MANIFOLD CONNECTIONS</b>			
To be purchased separately - Refer to Catalog 51-M for selection of fittings:			
1x 58456-xx Inlet			
1x 58456-1/4 Return from manifold (Cap with 1/4" female thread for pressure gauge)			
8400-1/4-PPB 1/4" pipe plug (If no pressure gauge is used)			
1x 45529-xx Return from pressure relief valve			
1x 45529-xx Return from flow back			
1x 45529-xx Return from regulation valve			
1x 45529-xx Return from master valve			
1x 45529-P Quick Connect plug			
5x 45529-xx Outlet – sections			
1x 45529-P Plug for flow back line on manifold			
<b>KITS</b>			
	904-301	844E, 5-Section, Comm., Speed .....	€ 1581,56
	903-602	Bracket, Simple .....	117,17
	96ET10-8D	Speed Sensor with Deutsch Connector, 8 m .....	67,18
	199-314	Spray Cable, 5-Section, Master, Flow, Speed .....	449,49
	58570-5-435EC-3FB ***	5-Section Valve with Flow Back .....	1.259,95
	AB98499-KIT ***	430 Mounting Kit (4 Bolts + O-Ring) .....	6,48
	98504-7 ***	Master Valve, Regulation Valve, Filter, Pressure Relief Valve, Flow Meter (Turbine) 9,5 – 225 l/min .....	1459,85
<b>ACCESSORIES</b>			
	99ET017-6	Speed sensor with 7P connector, 6 m .....	101,19
	96ET17-3	Communication Cable/Console <=> Sub-D .....	67,06
	98ET05_S13-4	Extension for Main Cable, 4 m .....	213,94
	96ET14	Battery Cable .....	45,61

\*\*\* Subject to WHE Discount

## TEEJET 844E

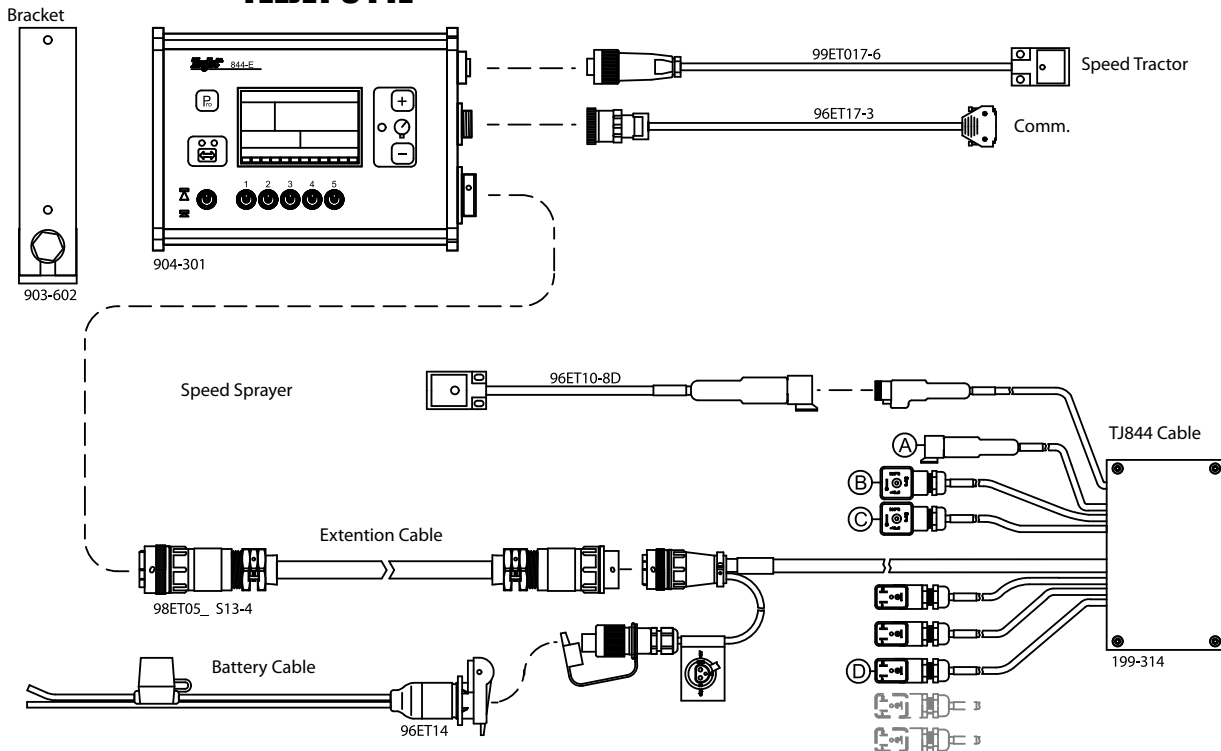

## 430 Manifold With Flow Meter

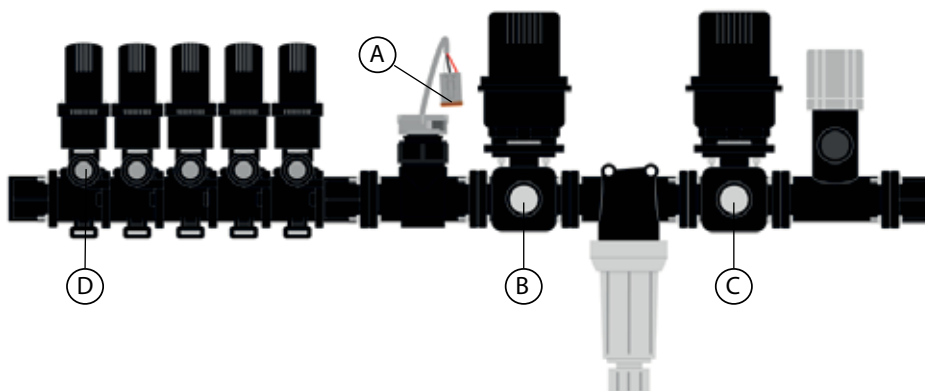













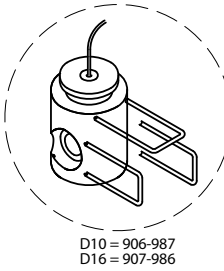
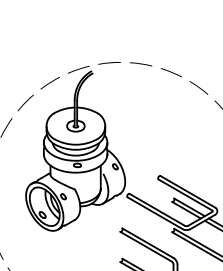
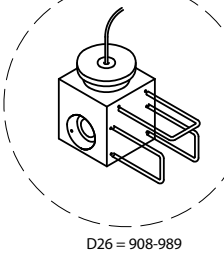
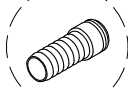
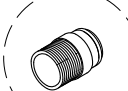

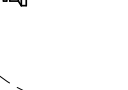
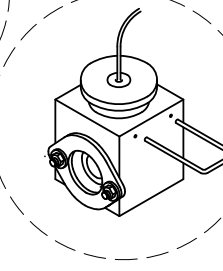
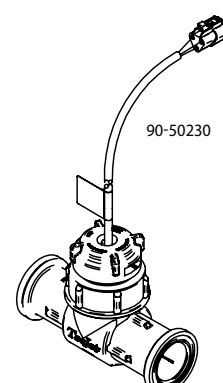
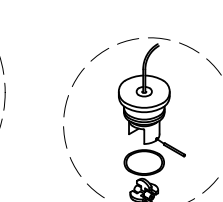
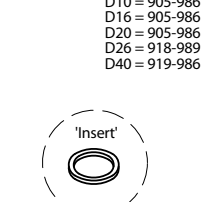
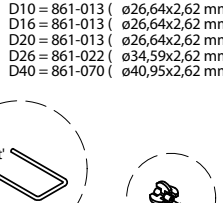
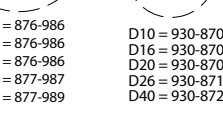

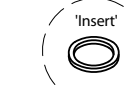
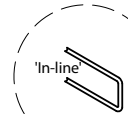











## 844E KIT - 7 SECTION

	PART NO.	DESCRIPTION	EURO
<b>MANIFOLD CONNECTIONS</b>	<b>KITS</b>		
To be purchased separately - Refer to Catalog 51-M for selection of fittings:	904-305	844E, 7-Section, Comm., Speed .....	€ 1659,79
1x 58456-xx Inlet	903-602	Bracket, Simple .....	117,17
1x 58456-1/4 Return from manifold (Cap with 1/4" female thread for pressure gauge)	96ET10-8D	Speed Sensor with Deutsch Connector, 8 m.....	67,18
8400-1/4-PPB 1/4" pipe plug (If no pressure gauge is used)	199-312	Spray Cable, 7-Section, Master, Flow, Speed .....	486,44
1x 45529-xx Return from pressure relief valve	58570-5-437EC-3FB ***	7-Section Valves with Flow Back .....	1.472,66
1x 45529-xx Return from flow back	AB98499-KIT ***	430 Mounting Kit (4 Bolts + O-Ring) .....	6,48
1x 45529-xx Return from regulation valve	98504-7 ***	Master Valve, Regulation Valve, Filter, Pressure Relief Valve, Flow Meter (Turbine) 9,5 – 225 l/min.....	1459,85
1x 45529-xx Return from master valve	<b>ACCESSORIES</b>		
1x 45529-P Quick Connect plug	99ET017-6	Speed Sensor with 7P Connector, 6 m .....	101,19
7x 45529-xx Outlet – sections	96ET17-3	Communication Cable/Console <=> Sub-D .....	67,06
1x 45529-P Plug for flow back line on manifold	98ET05_S13-4	Extension for Main Cable, 4 m .....	213,94
	96ET14	Battery Cable .....	45,61
*** Subject to WHE Discount			







## 844E KIT – 9-SECTION

	PART NO.	DESCRIPTION	EURO
<b>MANIFOLD CONNECTIONS</b>	<b>KITS</b>		
To be purchased separately - Refer to Catalog 51-M for selection of fittings:	904-302	844E, 7-Section, Comm., Speed. ....	€ 1739,16
1x 58456-xx Inlet	903-602	Bracket, Simple .....	117,17
1x 58456-1/4 Return from manifold (Cap with 1/4" female thread for pressure gauge)	96ET10-8D	Speed Sensor with Deutsch Connector, 8 m.....	67,18
8400-1/4-PPB 1/4" pipe plug (If no pressure gauge is used)	199-316	Spray Cable, 9-Section, Master, Flow, Speed .....	599,83
1x 45529-xx Return from pressure relief valve	58570-5-439EC-3FB ***	9-Section Valves with Flow Back .....	1.931,27
1x 45529-xx Return from flow back	AB98499-KIT ***	430 Mounting Kit (4 Bolts + O-Ring) .....	6,48
1x 45529-xx Return from regulation valve	98504-7 ***	Master Valve, Regulation Valve, Filter, Pressure Relief Valve, Flow Meter (Turbine) 9,5 – 225 m/min .....	1459,85
1x 45529-xx Return from Master valve	<b>ACCESSORIES</b>		
1x 45529-P Quick Connect plug	99ET017-6	Speed Sensor With 7P Connector, 6 m .....	101,19
9x 45529-xx Outlet – sections	96ET17-3	Communication Cable/Console <=> Sub-D .....	67,06
1x 45529-P Plug for flow back line on manifold	98ET05_S13-4	Extension for Main Cable, 4 m .....	213,94
	96ET14	Battery Cable .....	45,61
*** Subject to WHE Discount			

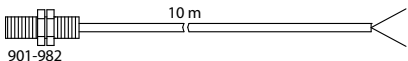
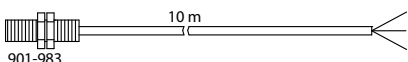
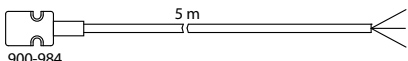
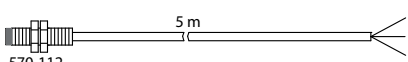
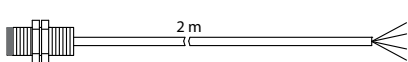
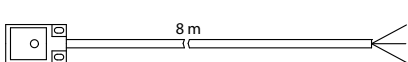
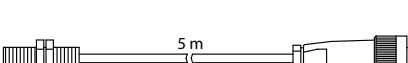
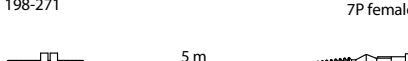
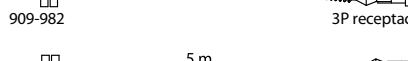
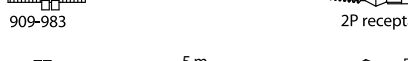
# SPRAYER FLOW METERS

	PART NO.	DESCRIPTION	EURO
<b>10 MM FLOW METERS – 1.5–85 L/MIN</b>			
	906-987	10 mm Flow Meter, 10 m Cable, without Connector .....	€ 367,47
D10 = 906-987 D16 = 907-986	<b>Fittings for 10 mm flow meter</b>		
	950-915	3/4" Male BSPT .....	59,16
D20 = 906-986	950-916	3/4" Female BSPT .....	32,59
	941-987	1/2" Hose Barb .....	48,25
D26 = 908-989	942-989	3/4" Threaded Connector Kit (1 Male, 1 Female Connector) .....	86,84
	<b>16 MM FLOW METERS – 5–160 L/MIN</b>		
Hose barb example	907-986	16 mm Flow Meter, 10 m Cable, without Connector .....	334,85
	<b>Fittings for 16 mm flow meter</b>		
Male BSPT example	941-991	TeeJet Valve Adapter .....	47,52
	950-988	3/4" Male BSPT .....	41,75
Female BSPT example	950-986	3/4" Female BSPT .....	45,19
	951-988	3/4" Hose Barb .....	39,71
Female BSPT example	952-988	1" Hose Barb .....	42,44
	931-988	Hardi EC "Twin" Connector Kit .....	162,31
Female BSPT example	<b>20 MM FLOW METERS – 20–250 L/MIN</b>		
	906-986	20 mm Flow Meter, 10 m Cable, without Connector .....	318,11
D40 = 909-986	<b>Fittings for 20 mm flow meter</b>		
	933-988	TeeJet Valve Adapter .....	51,07
90-50230	950-983	3/4" Male BSPT .....	39,01
	951-986	1" Female BSPT .....	48,61
	952-986	1" Male BSPT .....	48,61
	953-986	3/4" Hose Barb .....	44,48
	933-989	1" Hose Barb .....	21,91
	956-986	1 1/4" Hose Barb .....	24,75
	957-986	1 1/2" Hose Barb .....	41,75
	930-986	Hardi-Matic BK 20D Installation Kit .....	148,98
	931-986	Hardi-Ec 20D Installation Kit .....	127,70
	<b>26 MM FLOW METERS – 20–400 L/MIN</b>		
	908-989	26 mm Flow Meter, 10 m Cable, without Connector .....	399,60
	908-987	26 mm Flow Meter, 3 m Cable, JST Connector .....	475,87
	908-988	26 mm Flow Meter, 0.5 m Cable, Deutsch Connector .....	444,96
	<b>Fittings for 26 mm flow meter</b>		
	934-002	TeeJet Valve Adapter .....	54,64
	958-986	1 1/2" Male BSPT .....	86,81
	959-986	1 1/4" Hose Barb .....	45,87
	934-001	1 1/2" Hose Barb .....	90,51
	<b>40 MM FLOW METERS – 40–1000 L/MIN</b>		
	909-986	40 mm Flow Meter, 6 m Cable, without Connector .....	509,37
	<b>Fittings for the 40 mm flow meter</b>		
	961-986	2" Male BSPT .....	67,10
	962-986	2" Hose Barb .....	49,29
	<b>801 FLOW METER</b>		
	90-50230	1" 801 Flow Meter with 1" Straight Hose Barbs 9.5–227 l/min .....	468,17
	57-10122	2" 802 Flow Meter 12-490 l/min .....	487,68
	<b>SERVICE KIT</b>		
	905-986	Flow Meter Insert 10D/16D/20D, 10 m Cable .....	233,52
	918-989	Flow Meter Insert D26, 10 m Cable .....	276,26
	919-986	Flow Meter Insert 40D, 6 m Cable .....	256,52
	930-870	Flow Meter 10D/16D/20D Paddle Service Kit .....	39,30
	930-871	Flow Meter 26D Paddle Service Kit .....	68,98
	930-872	Flow Meter 40D Paddle Service Kit .....	109,67
	987-801	Flow Meter 10D Body .....	104,14
	987-816	Flow Meter 16D Body .....	111,24
	987-800	Flow Meter 20D Body .....	98,62
	987-826	Flow Meter 26D Body .....	157,22
		Clip, In-line and Insert .....	3,69
		Seal, In-line and Insert .....	0,71
	<b>10 mm flow meter</b>		
D10 = 861-014 ( ø27,00x2,50 mm)	<b>16 mm flow meter</b>		
D16 = 861-014 ( ø27,00x2,50 mm)	<b>20 mm flow meter</b>		
D20 = 861-014 ( ø27,00x2,50 mm)	<b>26 mm flow meter</b>		
D26 = 861-022 ( ø34,59x2,62 mm)	<b>40 mm flow meter</b>		
D40 = 861-071 ( ø52,07x2,62 mm)	<b>801 flow meter</b>		
See 'Seal In-line and Insert'	<b>Insert</b>		
	<b>Flow Meter Insert</b>		
D10 = 861-013 ( ø26,64x2,62 mm)	<b>Flow Meter Insert D26</b>		
D16 = 861-013 ( ø26,64x2,62 mm)	<b>Flow Meter Insert 40D</b>		
D20 = 861-013 ( ø26,64x2,62 mm)	<b>Flow Meter 10D/16D/20D Paddle Service Kit</b>		
D26 = 861-022 ( ø34,59x2,62 mm)	<b>Flow Meter 26D Paddle Service Kit</b>		
D40 = 861-070 ( ø40,95x2,62 mm)	<b>Flow Meter 40D Paddle Service Kit</b>		
	<b>Flow Meter 16D Body</b>		
D10 = 877-986	<b>Flow Meter 20D Body</b>		
D16 = 877-986	<b>Flow Meter 26D Body</b>		
D20 = 877-986	<b>Clip, In-line and Insert</b>		
D26 = 877-987	<b>Seal, In-line and Insert</b>		
D40 = 877-989	<b>Flow Meter 10D/16D/20D, 10 m Cable</b>		
	<b>Flow Meter Insert D26, 10 m Cable</b>		
D10 = 876-986	<b>Flow Meter Insert 40D, 6 m Cable</b>		
D16 = 876-986	<b>Flow Meter 10D/16D/20D Paddle Service Kit</b>		
D20 = 876-986	<b>Flow Meter 26D Paddle Service Kit</b>		
D26 = 877-987	<b>Flow Meter 40D Paddle Service Kit</b>		
D40 = 877-989	<b>Flow Meter 10D Body</b>		
	<b>Flow Meter 16D Body</b>		
D10 = 930-870	<b>Flow Meter 20D Body</b>		
D16 = 930-870	<b>Flow Meter 26D Body</b>		
D20 = 930-870	<b>Clip, In-line and Insert</b>		
D26 = 930-871	<b>Seal, In-line and Insert</b>		
D40 = 930-872	<b>Flow Meter 10D/16D/20D, 10 m Cable</b>		
	<b>Flow Meter Insert 40D, 6 m Cable</b>		
D10 = 930-870	<b>Flow Meter 10D/16D/20D Paddle Service Kit</b>		
D16 = 930-870	<b>Flow Meter 26D Paddle Service Kit</b>		
D20 = 930-870	<b>Flow Meter 40D Paddle Service Kit</b>		
D26 = 930-871	<b>Flow Meter 10D Body</b>		
D40 = 930-872	<b>Flow Meter 16D Body</b>		
	<b>Flow Meter 26D Body</b>		
D10 = 930-870	<b>Clip, In-line and Insert</b>		
D16 = 930-870	<b>Seal, In-line and Insert</b>		
D20 = 930-870	<b>Flow Meter 10D/16D/20D, 10 m Cable</b>		
D26 = 930-871	<b>Flow Meter Insert D26, 10 m Cable</b>		
D40 = 930-872	<b>Flow Meter Insert 40D, 6 m Cable</b>		
	<b>Flow Meter 10D/16D/20D Paddle Service Kit</b>		
D10 = 930-870	<b>Flow Meter 26D Paddle Service Kit</b>		
D16 = 930-870	<b>Flow Meter 40D Paddle Service Kit</b>		
D20 = 930-870	<b>Flow Meter 10D Body</b>		
D26 = 930-871	<b>Flow Meter 16D Body</b>		
D40 = 930-872	<b>Flow Meter 20D Body</b>		
	<b>Flow Meter 26D Body</b>		
D10 = 930-870	<b>Clip, In-line and Insert</b>		
D16 = 930-870	<b>Seal, In-line and Insert</b>		
D20 = 930-870	<b>Flow Meter 10D/16D/20D, 10 m Cable</b>		
D26 = 930-871	<b>Flow Meter Insert D26, 10 m Cable</b>		
D40 = 930-872	<b>Flow Meter Insert 40D, 6 m Cable</b>		
	<b>Flow Meter 10D/16D/20D Paddle Service Kit</b>		
D10 = 930-870	<b>Flow Meter 26D Paddle Service Kit</b>		
D16 = 930-870	<b>Flow Meter 40D Paddle Service Kit</b>		
D20 = 930-870	<b>Flow Meter 10D Body</b>		
D26 = 930-871	<b>Flow Meter 16D Body</b>		
D40 = 930-872	<b>Flow Meter 20D Body</b>		
	<b>Flow Meter 26D Body</b>		
D10 = 930-870	<b>Clip, In-line and Insert</b>		
D16 = 930-870	<b>Seal, In-line and Insert</b>		
D20 = 930-870	<b>Flow Meter 10D/16D/20D, 10 m Cable</b>		
D26 = 930-871	<b>Flow Meter Insert D26, 10 m Cable</b>		
D40 = 930-872	<b>Flow Meter Insert 40D, 6 m Cable</b>		
	<b>Flow Meter 10D/16D/20D Paddle Service Kit</b>		
D10 = 930-870	<b>Flow Meter 26D Paddle Service Kit</b>		
D16 = 930-870	<b>Flow Meter 40D Paddle Service Kit</b>		
D20 = 930-870	<b>Flow Meter 10D Body</b>		
D26 = 930-871	<b>Flow Meter 16D Body</b>		
D40 = 930-872	<b>Flow Meter 20D Body</b>		
	<b>Flow Meter 26D Body</b>		
D10 = 930-870	<b>Clip, In-line and Insert</b>		
D16 = 930-870	<b>Seal, In-line and Insert</b>		
D20 = 930-870	<b>Flow Meter 10D/16D/20D, 10 m Cable</b>		
D26 = 930-871	<b>Flow Meter Insert D26, 10 m Cable</b>		
D40 = 930-872	<b>Flow Meter Insert 40D, 6 m Cable</b>		
	<b>Flow Meter 10D/16D/20D Paddle Service Kit</b>		
D10 = 930-870	<b>Flow Meter 26D Paddle Service Kit</b>		
D16 = 930-870	<b>Flow Meter 40D Paddle Service Kit</b>		
D20 = 930-870	<b>Flow Meter 10D Body</b>		
D26 = 930-871	<b>Flow Meter 16D Body</b>		
D40 = 930-872	<b>Flow Meter 20D Body</b>		
	<b>Flow Meter 26D Body</b>		
D10 = 930-870	<b>Clip, In-line and Insert</b>		
D16 = 930-870	<b>Seal, In-line and Insert</b>		
D20 = 930-870	<b>Flow Meter 10D/16D/20D, 10 m Cable</b>		
D26 = 930-871	<b>Flow Meter Insert D26, 10 m Cable</b>		
D40 = 930-872	<b>Flow Meter Insert 40D, 6 m Cable</b>		
	<b>Flow Meter 10D/16D/20D Paddle Service Kit</b>		
D10 = 930-870	<b>Flow Meter 26D Paddle Service Kit</b>		
D16 = 930-870	<b>Flow Meter 40D Paddle Service Kit</b>		
D20 = 930-870	<b>Flow Meter 10D Body</b>		
D26 = 930-871	<b>Flow Meter 16D Body</b>		
D40 = 930-872	<b>Flow Meter 20D Body</b>		
	<b>Flow Meter 26D Body</b>		
D10 = 930-870	<b>Clip, In-line and Insert</b>		
D16 = 930-870	<b>Seal, In-line and Insert</b>		
D20 = 930-870	<b>Flow Meter 10D/16D/20D, 10 m Cable</b>		
D26 = 930-871	<b>Flow Meter Insert D26, 10 m Cable</b>		
D40 = 930-872	<b>Flow Meter Insert 40D, 6 m Cable</b>		
	<b>Flow Meter 10D/16D/20D Paddle Service Kit</b>		
D10 = 930-870	<b>Flow Meter 26D Paddle Service Kit</b>		
D16 = 930-870	<b>Flow Meter 40D Paddle Service Kit</b>		
D20 = 930-870	<b>Flow Meter 10D Body</b>		
D26 = 930-871	<b>Flow Meter 16D Body</b>		
D40 = 930-872	<b>Flow Meter 20D Body</b>		
	<b>Flow Meter 26D Body</b>		
D10 = 930-870	<b>Clip, In-line and Insert</b>		
D16 = 930-870	<b>Seal, In-line and Insert</b>		
D20 = 930-870	<b>Flow Meter 10D/16D/20D, 10 m Cable</b>		
D26 = 930-871	<b>Flow Meter Insert D26, 10 m Cable</b>		
D40 = 930-872	<b>Flow Meter Insert 40D, 6 m Cable</b>		
	<b>Flow Meter 10D/16D/20D Paddle Service Kit</b>		
D10 = 930-870	<b>Flow Meter 26D Paddle Service Kit</b>		
D16 = 930-870	<b>Flow Meter 40D Paddle Service Kit</b>		
D20 = 930-870	<b>Flow Meter 10D Body</b>		
D26 = 930-871	<b>Flow Meter 16D Body</b>		
D40 = 930-872	<b>Flow Meter 20D Body</b>		
	<b>Flow Meter 26D Body</b>		
D10 = 930-870	<b>Clip, In-line and Insert</b>		
D16 = 930-870	<b>Seal, In-line and Insert</b>		
D20 = 930-870	<b>Flow Meter 10D/16D/20D, 10 m Cable</b>		
D26 = 930-871	<b>Flow Meter Insert D26, 10 m Cable</b>		
D40 = 930-872	<b>Flow Meter Insert 40D, 6 m Cable</b>		
	<b>Flow Meter 10D/16D/20D Paddle Service Kit</b>		
D10 = 930-870	<b>Flow Meter 26D Paddle Service Kit</b>		
D16 = 930-870	<b>Flow Meter 40D Paddle Service Kit</b>		
D20 = 930-870	<b>Flow Meter 10D Body</b>		
D26 = 930-871	<b>Flow Meter 16D Body</b>		
D40 = 930-872	<b>Flow Meter 20D Body</b>		
	<b>Flow Meter 26D Body</b>		
D10 = 930-870	<b>Clip, In-line and Insert</b>		
D16 = 930-870	<b>Seal, In-line and Insert</b>		
D20 = 930-870	<b>Flow Meter 10D/16D/20D, 10 m Cable</b>		
D26 = 930-871	<b>Flow Meter Insert D26, 10 m Cable</b>		
D40 = 930-872	<b>Flow Meter Insert 40D, 6 m Cable</b>		
	<b>Flow Meter 10D/16D/20D Paddle Service Kit</b>		
D10 = 930-870	<b>Flow Meter 26D Paddle Service Kit</b>		
D16 = 930-870	<b>Flow Meter 40D Paddle Service Kit</b>		
D20 = 930-870	<b>Flow Meter 10D Body</b>		
D26 = 930-871	<b>Flow Meter 16D Body</b>		
D40 = 930-872	<b>Flow Meter 20D Body</b>		
	<b>Flow Meter 26D Body</b>		
D10 = 930-870	<b>Clip, In-line and Insert</b>		
D16 = 930-870	<b>Seal, In-line and Insert</b>		
D20 = 930-870	<b>Flow Meter 10D/16D/20D, 10 m Cable</b>		
D26 = 930-871	<b>Flow Meter Insert D26, 10 m Cable</b>		

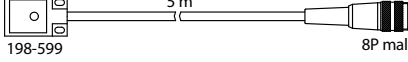
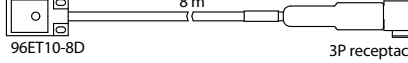
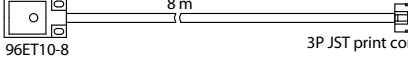
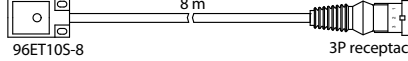
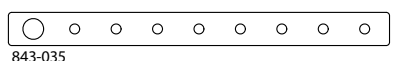
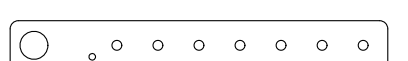
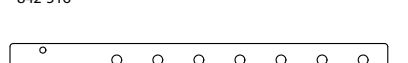
# SENSORS

	PART NO.	DESCRIPTION	EURO
	901-982	Sensor Kit, 2-Core, 10 m, Complete Kit with Sensor, Bracket and 2 Magnets	€ 62,30
	931-983	Sensor Kit, 3-Core, 10 m, Complete Kit with Sensor, Bracket and 2 Magnets	81,59
	933-983	Sensor Kit, Inductive, 5 Meter, Complete Kit with Sensor and Bracket	97,90
	932-983	Sensor Kit, 3-Core, 5 Meter, Complete Kit with Sensor, Bracket and PTO Magnet Ring	101,60
	930-984	Sensor Kit, 3-Core, 5 Meter, Bipolar, Complete Kit with Mini Sensor for Prop Shaft, Bracket And 2 Magnets	85,27
	570-112		
	904-151		
	96ET10		
	198-271		
	909-982		
	909-983		
	198-224		
	198-247		
	198-556		
	99ET017-6		
	198-599		
	96ET10-8D		
	96ET10-8		
	96ET10S-8		
	843-035		
	842-516		
	841-530		
	775-803		
		<b>KITS</b>	
		<b>SENSORS</b>	
		<b>SENSORS WITH CONNECTOR</b>	
		<b>FEATURES</b>	
		2-core sensor: activated by a magnet south or north pol.	
		3- core sensor: activated by a magnet south pol.	
		3-core sensor, bipolar: activated by a magnet south and north pol.	
		Inductive sensor: activated by metal.	
		Capacitive: Activated by e.g. Grain.	

# LH1000

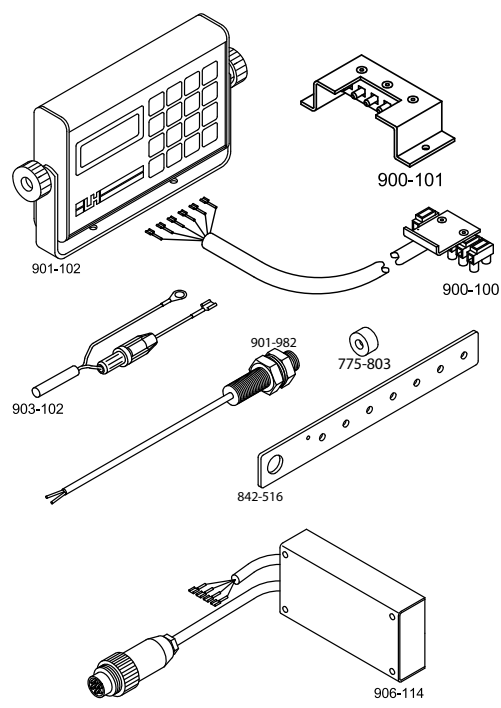
	PART NO.	DESCRIPTION	EURO
	<b>KITS</b>		
	904-102	LH1000 Tractor Monitor Kit .....	€ 594,50
	900-103	LH1000 Additional Mounting Kit (with 900-100 & 900-101), (for moving LH1000 between two vehicles) .....	236,52
	931-982	Sensor Kit, 2-Core, 10 m, Complete Kit Including Sensor, Bracket and 2 Magnets .....	62,30
	906-114	Interface DIN/ISO for LH1000/1200, DIN9684-1, ISO11786 .....	240,91
	<b>ACCESSORIES</b>		
	901-102	LH1000 Monitor, Head Only .....	477,43
	901-982	Sensor, 2-Core, 10 m .....	59,31
	842-516	Bracket .....	8,08
	775-803	Magnet .....	2,99
900-100	LH1000 Multi Plug, Monitor Part .....	38,59	
900-101	LH1000 Multi Plug, Tractor Part .....	26,71	
903-102	Power Cable for LH1000 Series .....	14,10	
<b>FEATURES</b>			
904-102: Complete kit includes LH1000 monitor, speed sensor, implement sensor and installation kit.			
Speed (kmh), area (Ha), time (hr/min), RPM (rev/min), Distance (m), counting (units).			

# LH1200

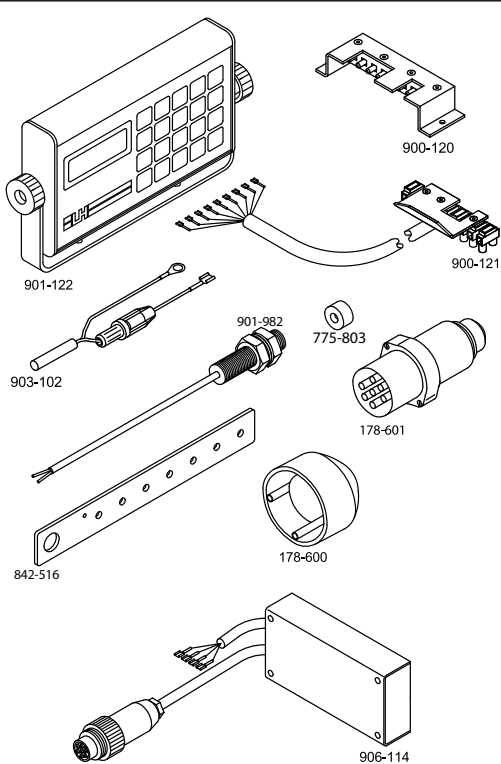
	PART NO.	DESCRIPTION	EURO
	<b>KITS</b>		
	903-122	LH1200 Tractor Monitor Kit .....	€ 904,51
	900-123	LH1200 Additional Mounting Kit, (for moving LH1200 between two vehicles) .....	213,55
	931-982	Sensor Kit, 2-Core, 10 m, Complete Kit Including Sensor, Bracket And Two Magnets .....	62,30
	906-114	Interface Din/ISO for LH1000/1200, Din9684-1, ISO11786 .....	240,91
	<b>ACCESSORIES</b>		
	901-122	LH1200 Monitor, Head Only .....	725,75
	901-982	Sensor, 2-Core, 10 m .....	59,31
	842-516	Bracket .....	8,08
	775-803	Magnet .....	2,99
900-121	LH1200 Multi Plug, Monitor Part .....	50,75	
900-120	LH1200 Multi Plug, Tractor Part .....	43,47	
903-102	Power Cable For LH1000 Series .....	14,10	
178-600	7P Trailer Socket .....	13,10	
178-601	7P Trailer Plug .....	11,91	
<b>FEATURES</b>			
903-122: Complete kit includes LH1200, speed sensor, implement sensor, multi plug, 7P trailer connector and installation kit.			
Application rate (l/Ha), Consumption (l), Speed (kmh), Area (Ha), Time (hr/min), RPM (rev/min), Distance (m), Counting (Units).			



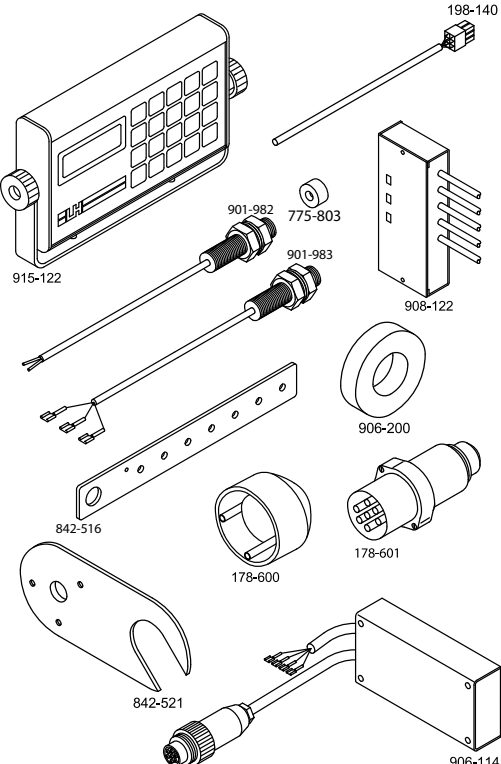

# LH1200 S

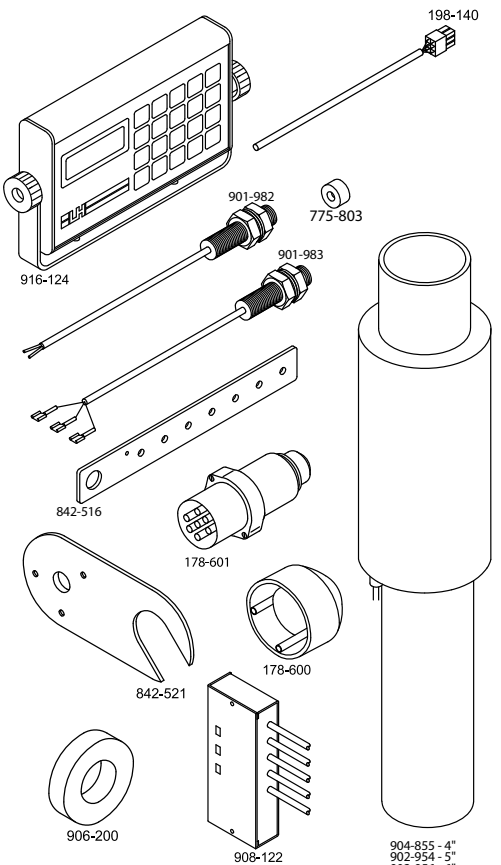
	PART NO.	DESCRIPTION	EURO
	<b>KITS</b>		
	915-122-xx	LH1200 S Sprayer Monitor, without Mounting Kit .....	€ 714,67
	916-123-xx	LH1200 S Mounting Kit, with Speed & 'Ha On-Off' Sensor, Signal Distributor Box with Switches and 7P Trailer Connector .....	342,91
	931-982	Sensor Kit, 2-Core, 10 m, Complete Kit Includes Sensor, Bracket and 2 Magnets .....	62,30
	932-983	Sensor Kit, 3-Core, 5 Meter, with Bracket and PTO Magnet Ring for RPM Measurement. ....	101,60
	906-114	Interface DIN/ISO for LH1000/1200, Din9684-1, ISO11786 .....	240,91
	<b>ACCESSORIES</b>		
	901-983	Sensor, 3-Core, 10 m .....	81,59
	901-982	Sensor, 2-Core, 10 m .....	59,31
	842-516	Bracket .....	8,08
	775-803	Magnet .....	2,99
	906-200	PTO Magnet Ring .....	28,24
908-122	Signal Distributor Box with Switches .....	169,93	
198-140	LH1200 S Main Cable .....	28,95	
842-521	Mounting Plate For Trailer Socket .....	13,33	
178-600	7P Trailer Socket .....	13,10	
178-601	7P Trailer Plug .....	11,91	
<b>FEATURES</b>			
Application rate (l/Ha), flow (l/min), consumption (l), speed (kmh), area (Ha), time (hr/min), RPM (rev/min), distance (m), counting (units), manual compensation for liter and area when a section is closed.			

# LH1200 SLURRY

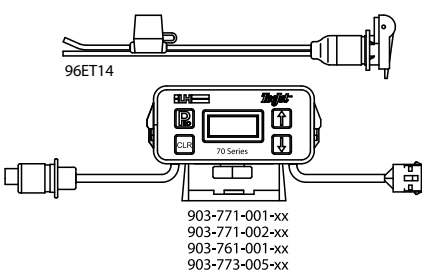
	PART NO.	DESCRIPTION	EURO
	<b>KITS</b>		
	917-124-xx	LH1200 Slurry Monitor Kit .....	€ 1107,43
	931-982	Sensor Kit, 2-Core, 10 m, Complete Kit Includes Sensor, Bracket and 2 Magnets .....	62,30
	932-983	Sensor Kit, 3-Core, 5 m, with Bracket and PTO Magnet Ring for RPM Measurement .....	101,60
	<b>FLOW METERS</b>		
	904-855	Slurry Flow Meter M110, 4" (0,5-5 m <sup>3</sup> /min) .....	2661,00
	902-954	Slurry Flow Meter M140, 5" (1-10 m <sup>3</sup> /min) .....	2661,00
	902-956	Slurry Flow Meter M160, 6" (1-15 m <sup>3</sup> /min) .....	2661,00
	- Flanges NOT Included		
	<b>ACCESSORIES</b>		
	901-983	Sensor, 3-Core, 10 m .....	81,59
	901-982	Sensor, 2-Core, 10 m .....	59,31
842-516	Bracket .....	8,08	
775-803	Magnet .....	2,99	
906-200	PTO Magnet Ring .....	28,24	
908-122	Signal Distributor Box with Switches .....	169,93	
198-140	LH1200 S Main Cable .....	28,95	
842-521	Mounting Plate for Trailer Socket .....	13,33	
178-600	7P Trailer Socket .....	13,10	
178-601	7P Trailer Plug .....	11,91	
<b>FEATURES</b>			
917-124: Complete kit includes TJ1200 Slurry monitor, speed sensor, implement sensor, signal distributor box with switches and 7P trailer connector; excludes flow meter			
Application rate (m <sup>3</sup> /Ha), consumption (m <sup>3</sup> ), flow (m <sup>3</sup> /hr), speed (kmh), area (Ha), time (hr/min).			

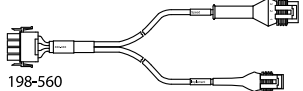
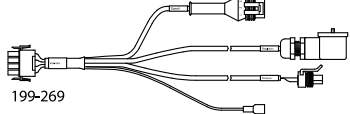
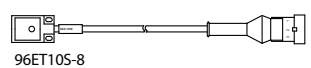
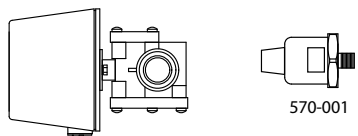
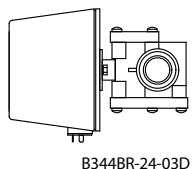
# TeeJet<sup>®</sup> TECHNOLOGIES 70 SERIES

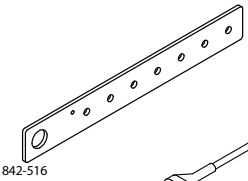
	PART NO.	DESCRIPTION	EURO	
 <p>96ET14</p> <p>903-771-001-xx 903-771-002-xx 903-761-001-xx 903-773-005-xx</p>  <p>198-619</p>  <p>198-560</p>  <p>199-269</p>  <p>96ET105-8</p>  <p>570-001</p>  <p>B344BR-24-03D</p>  <p>775-803</p>  <p>909-983</p>  <p>842-516</p>	<p><b>KITS</b></p> <p>990-070-xx TeeJet 71 Speed/Area/Distance .....</p> <p>990-072-xx TeeJet 71 RPM .....</p> <p>990-077-xx TeeJet 73 Sprayer Regulation, Pressure Based with Regulating Valve .....</p> <p>990-082-xx TeeJet 71 Speed/Area/Distance, 2 Sensors .....</p> <p><b>ACCESSORIES</b></p> <p>903-771-001-xx 71 Single-Sensor Monitor, Speed/Area/Distance .....</p> <p>903-771-002-xx 71 Single-Sensor Monitor, RPM .....</p> <p>903-773-005-xx 73 Multi-Purpose Controller, Sprayer .....</p> <p>903-761-001-xx 71 Single-Sensor Monitor .....</p> <p>96ET14 Battery Cable .....</p> <p>198-619 Speed/RPM Sensor .....</p> <p>B344BR-24-03D Regulating Valve, 2-Way, 1" BSPT, 6 Section, DIN Connector ..</p> <p>199-269 73 Sprayer Adaptor Cable .....</p> <p>96ET105-8 Proximity Sensor, 8 Meter, 3P Connector .....</p> <p>570-001 Pressure Sensor, 10 Bar, 1/4" .....</p> <p>198-560 71 Speed/Area/Distance Adapter Cable .....</p> <p>909-983 Sensor, 2-Core, 5 m, 2P Connector .....</p> <p>842-516 Bracket .....</p> <p>775-803 Magnet .....</p> <p><b>FEATURES</b></p> <p>990-070-xx: Complete kit includes controller, speed sensor and cable.</p> <p>990-072-xx: Complete kit includes controller, RPM sensor and cable.</p> <p>990-077-xx: Complete kit includes controller, speed sensor, pressure sensor, regulating valve and cable.</p> <p>990-082-xx: Complete kit includes controller, speed sensor, Ha on-off sensor and cable.</p>	<p>€ 425,47</p> <p>420,36</p> <p>1031,80</p> <p>477,93</p> <p>241,29</p> <p>246,57</p> <p>482,60</p> <p>241,29</p> <p>45,61</p> <p>149,57</p> <p>322,55</p> <p>181,40</p> <p>74,51</p> <p>180,37</p> <p>59,28</p> <p>57,37</p> <p>8,08</p> <p>2,99</p>		
	<i>xx = Language</i>			

# 500 SLURRY CONTROLLER

	PART NO.	DESCRIPTION	EURO
	<b>KITS</b>		
	905-510-xx	TJ500 Slurry Controller, Hydraulic.....	€ 1879,97
	905-244	TJ500 Printer, with Cable .....	787,32
	<b>ACCESSORIES</b>		
	844-045	Mounting Bracket, Vehicle.....	4,82
	862-817	Thumb Screw .....	2,52
	842-526	Bracket for Machine Connector.....	22,88
	178-344	Dust Cap for Machine Connector .....	19,85
	<b>FEATURES</b>		
	905-510: Complete TJ500 controller kit includes mounting bracket and accessories for machine connector.		
	<i>xx = Language</i>		

# 500 SLURRY KIT

	PART NO.	DESCRIPTION	EURO
	<b>KITS</b>		
	910-300	TJ500 Slurry Installation Kit (See Description Below) .....	€ 1333,73
	910-303	TJ500 Slurry Installation Kit (See Description Below) .....	1029,12
	910-299	Junction Box with Cable.....	670,49
	931-982	Sensor Kit, 2-Core, 10 m, Complete Kit Includes Sensor, Bracket and 2 Magnets .....	62,30
	932-983	Sensor Kit, 3-Core, 5 m, with Bracket and PTO Magnet Ring for RPM Measurement .....	101,60
	<b>FLOW METERS</b>		
	904-855	Slurry Flow Meter M110, 4" (0,5-5 m <sup>3</sup> /min) .....	2661,00
	902-954	Slurry Flow Meter M140, 5" (1-10 m <sup>3</sup> /min) .....	2661,00
	902-956	Slurry Flow Meter M160, 6" (1-15 m <sup>3</sup> /min) .....	2661,00
	<i>- No Flanges Included</i>		
	<b>ACCESSORIES</b>		
	901-982	Sensor, 2-Core, 10 m .....	59,31
	901-983	Sensor, 3-Core, 10 m .....	81,59
	197-048	Cable, with Din Connector.....	53,83
	842-516	Bracket .....	8,08
	775-803	Magnet.....	2,99
900-164	Circuit Board.....	191,97	
<b>FEATURES</b>			
910-300 (Slurry tankers with centrifugal pump): Complete kit includes junction box, speed sensor, RPM sensor (pump), RPM sensor (shopper) and cables for el-hydraulic valves; excludes flow meter.			
910-303 (Slurry vacuum tankers): Complete kit includes junction box, speed sensor, Implement sensor and cables for el-hydraulic valves; excludes flow meter.			
TJ500 Slurry installation kits for slurry tankers is used where the flow is controlled via a hydraulic cylinder (the cylinder must be controlled via el-hydraulic).			

# INTELLITRAM

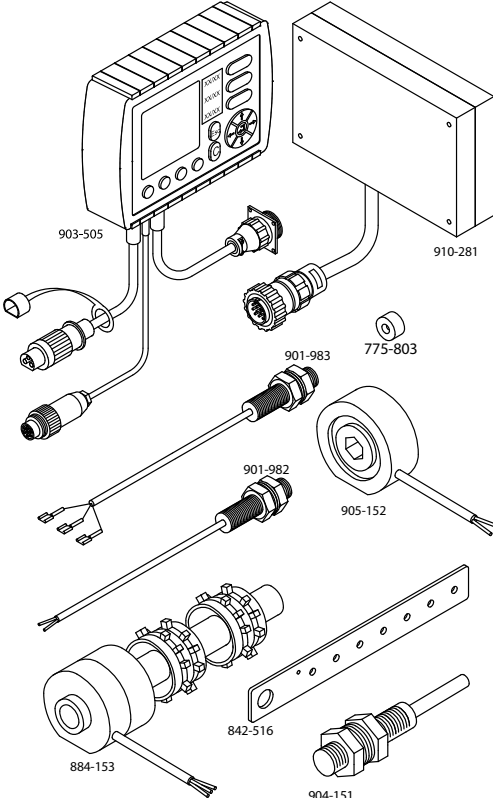
	PART NO.	DESCRIPTION	EURO
	<b>KITS</b>		
	903-505-xx	IntelliTram 500 Controller, without Mounting Kit .....	€ 953,33
	910-282	IntelliTram Mounting Kit .....	384,45
	903-152	Clutch Kit (2) For 17 mm Hex. Shaft, with Pipe & Seed Roll .....	885,37
	904-151	Hopper Level Sensor, M30.....	216,53
	931-982	Sensor Kit, 2-Core, 10 m, Complete Kit Includes Sensor, Bracket and 2 Magnets .....	62,30
	931-983	Sensor Kit, 3-Core, 10 m, with Bracket & Magnet for Fan RPM Measurement .....	81,59
	905-152	Drill Shaft Control, 17 mm Hex Shaft.....	468,41
	904-151	Hopper Sensor.....	216,53
	<b>ACCESSORIES</b>		
	901-983	Sensor, 3-Core, 10 m .....	81,59
	901-982	Sensor, 2-Core, 10 m .....	59,31
	842-516	Bracket .....	8,08
	775-803	Magnet.....	2,99
910-281	IntelliTram Junction Box, with Circuit Board .....	351,31	
884-153	Clutch with Pipe and Seed Roll .....	356,57	
<b>FEATURES</b>			
910-282: Complete kit includes junction box and three complete 2-core, 5 meter sensor kits.			
Control of clutches using two outputs (approx. 50 rhythms), present application rate (kg/ha), consumption (kg), kg left, flow (ha/hr), speed (kmh), area (ha), distance (m), alarms, job data.			

# LH4000 SPRAYER CONTROLLER

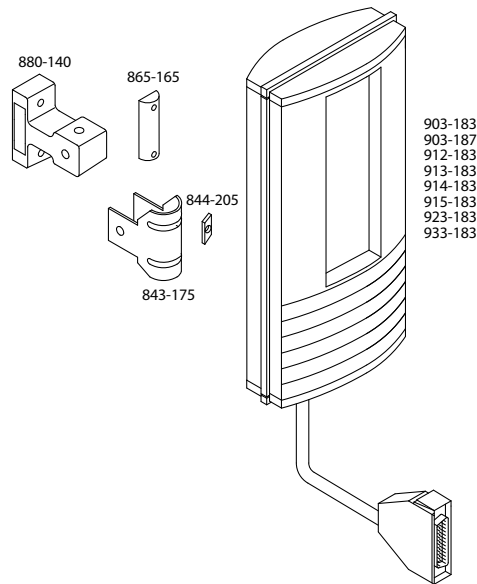
	PART NO.	DESCRIPTION	EURO
	<b>KITS</b>		
	903-183*	LH4000 Sprayer Computer, DK/S/UK .....	€ 1625,71
	903-187*	LH4000 Sprayer Computer, D/CZ/HG .....	1555,77
	912-183*	LH4000 Sprayer Computer, UK/E/P .....	1625,71
	913-183*	LH4000 Sprayer Computer, CZ/D/F .....	1625,71
	914-183*	LH4000 Sprayer Computer, D/CZ/PL .....	1625,71
	915-183*	LH4000 Sprayer Computer, UK/D/F .....	1625,71
	923-183*	LH4000 Sprayer Computer, F/D/I .....	1625,71
	933-183*	LH4000 Sprayer Computer, F/NL/FL.....	1625,71
	904-182	*Mounting Bracket Included (880-140, 865-165, 844-205, 843-175).....	84,83
	<b>ACCESSORIES</b>		
	880-140	Bracket, Vehicle Part.....	39,01
	865-165	Plastic Spacer .....	13,02
	843-175	Bracket, Controller Part .....	24,12
844-205	Nut.....	4,97	
<b>FEATURES</b>			
The LH4000 spray controller provides a comprehensive picture of the actual working conditions of a sprayer. It also provide a selectable 'other implement' feature for e.g. speed & area recording etc.			
Automatic speed and boom status compensated application rate control. The forward speed, spray-boom status, and the actual application-rate are permanently displayed.			
The operator has a large selection of specific information, e.g. as worked area, liter sprayed, consumption, actual l/min output, etc.			





# LH5000 & LH5000 GPS

	PART NO.	DESCRIPTION	EURO
	<b>KITS</b>		
	991-181	LH5000 Controller with Installation Kit (900-181) .....	€ 2590,97
	917-181	LH5000 Controller, without Installation Kit .....	2167,74
	907-184	LH5000 GPS Controller, without Installation Kit .....	2775,57
	900-181	Installation Kit, Includes Junction Box, Speed & 'Ha On-Off' Sensor and 7P Trailer Connector .....	437,43
	931-982	Sensor Kit, 2-Core, 10 m, Complete Kit Includes Sensor, Bracket and 2 Magnets .....	62,30
	904-181	Mounting Bracket with Cable .....	159,35
	905-242	Printer For LH5000, 110 mm .....	787,32
	<b>ACCESSORIES</b>		
	901-982	Sensor, 2-Core, 10 m .....	59,31
	842-516	Bracket .....	8,08
	775-803	Magnet .....	2,99
900-303	Circuit Board .....	69,67	
866-012	Junction Box .....	10,32	
842-521	Mounting Plate for Trailer Socket .....	13,33	
178-601	7P Trailer Plug .....	11,91	
178-600	7P Trailer Socket .....	13,10	
865-165	Plastic Spacer .....	13,02	
843-175	Bracket, Controller Part .....	24,12	
844-205	Nut .....	4,97	
<b>FEATURES</b>			
900-181: Complete installation kit includes junction box, controller bracket, speed sensor, Ha on-off sensor, trailer plug and cables.			
LH5000: Multi controller includes software for sprayers, granular spreaders, drills, slurry tankers, baler and 'other implement'.			
Job and print function. LH5000 GPS can do variable rate control (via RS232 port).			

# LH5000 & LH5000 GPS - DRILL

	PART NO.	DESCRIPTION	EURO
	<b>KITS</b>		
	921-180	LH5000 Tramline Interface .....	€ 303,89
	903-152	Clutch Kit, For 17 mm Hex Shaft (2 Clutches) .....	885,37
	904-151	Hopper Sensor .....	216,53
	905-152	Drill Shaft Control, 17 mm Hex Shaft .....	468,41
	931-982	Sensor Kit, 2-Core, 10 m, Complete Kit Includes Sensor, Bracket and 2 Magnets .....	62,30
	<b>ACCESSORIES</b>		
	901-982	Sensor, 2-Core, 10 m .....	59,31
	842-516	Bracket .....	8,08
	775-803	Magnet .....	2,99
	900-315	Circuit Board .....	124,02
	<b>FEATURES</b>		
921-180: Tramline interface, makes it possible to control tramlines with LH5000.			
905-152 drill shaft sensor, makes it possible to see the kg & kg/ha in the display.			
904-151 hopper sensor, add warning if the hopper is empty.			
931-982 implement sensor, makes it possible to control the tramline via the marker.			

# LH5000 & LH5000 GPS - SLURRY









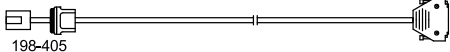
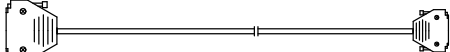

	PART NO.	DESCRIPTION	EURO
	<b>KITS</b>		
	910-219-xx	LH5000 Slurry Installation Kit, Hydraulic.....	€ 1835,57
	910-214	LH5000 Mounting.....	445,52
	910-216	Junction Box with Cable.....	675,37
	931-982	Sensor Kit, 2-Core, 10 m, Complete Kit Includes Sensor, Bracket and 2 Magnets.....	62,30
	932-983	Sensor Kit, 3-Core, 5 m, with Bracket And PTO Magnet Ring for RPM Measurement.....	101,60
	<b>FLOW METERS</b>		
	904-855	Slurry Flow Meter M110, 4" (0,5-5 m <sup>3</sup> /min).....	2661,00
	902-954	Slurry Flow Meter M140, 5" (1-10 m <sup>3</sup> /min).....	2661,00
	902-956	Slurry Flow Meter M160, 6" (1-15 m <sup>3</sup> /min).....	2661,00
	- No Flanges Included		
	<b>ACCESSORIES</b>		
	901-982	Sensor, 2-Core, 10 m.....	59,31
	901-983	Sensor, 3-Core, 10 m.....	81,59
	197-048	Cable, with Din Connector.....	53,83
842-516	Bracket.....	8,08	
775-803	Magnet.....	2,99	
900-164	Circuit Board.....	191,97	
<b>FEATURES</b>			
910-219: Complete kit includes speed sensor, rpm sensor (pump), rpm sensor (shopper) and LH5000 mounting and cables for el-hydraulic valves; does not include flow meter.			
LH5000 installation kit for slurry tankers where the flow is controlled via a hydraulic cylinder (the cylinder must be controlled of el-hydraulic.)			

xx = Language

# LH865 GRAIN LOSS MONITOR

	PART NO.	DESCRIPTION	EURO	
<b>KITS</b>				
	990-865-xx	LH865 Grain Loss Monitor Kit, with Grain Loss Sensors. ....	€ 2186,31	
	907-865-xx	LH865 Grain Loss Monitor Kit, without Grain Loss Sensors. ....	1381,11	
	905-000	Sensor Kit For Grain Loss Monitor, Complete Kit Includes 2 Straw Walkers- & 1 Sieve Sensor. ....	805,04	
	908-012	Straw Walker Sensor Kit, (2 Pcs.).....	436,74	
	928-020	Sieve Sensor Kit, Includes Cable 198-312 (Steel 1648 mm) .....	381,81	
	<b>ACCESSORIES</b>			
	908-865	LH865 with Foot .....	1200,22	
	905-865	Multi Cable For LH865 with Plug.....	100,74	
	900-708	Light Sensor .....	37,02	
	866-012	Junction Box.....	10,32	
900-017	Print For Junction Box 1 .....	50,36		
900-013	Print For Junction Box 2 .....	37,02		
775-803	Magnet.....	2,99		
901-982	Sensor, 2-Core, 10 m .....	59,31		
842-516	Bracket .....	8,08		
927-021	Sieve Sensor, Steel 1648 mm, without Cable.....	370,75		
907-012	Straw Walker Sensor .....	217,95		
841-521	Mounting Bracket For Sieve Sensor .....	8,95		
198-312	Cable For Sieve Sensor, 1,6 m .....	34,90		
<b>FEATURES</b>				
<p>990-865: Complete kit includes LH865 monitor, grain loss sensors for straw walkers and sieves, speed sensor, light sensor and installation kit.</p>				
<p>907-865: LH865 monitor kit includes speed sensor, light sensor and installation kit.</p>				
<p>Grain loss monitor for straw walkers and sieves, includes compensation for speed and light.</p>				

# RS232 GPS CABLES

	PART NO.	DESCRIPTION	EURO
 198-286	<b>LH500/TJ500/RAUCH QUANTRON M</b>		
	198-286	RS232 Cable, Modular to 9P Male Sub.D Connector. ....	€ 40,93
 198-405	198-405	RS232 Cable, Modular to 9P Female Sub.D Connector. ....	42,47
	<b>LH6000/RAUCH QUANTRON P</b>		
 198-292	198-292	RS232 Cable, 25P Male to 9P Male Sub.D Connector. ....	90,80
	198-408	RS232 Cable, 25P Male to 9P Female Sub.D Connector. ....	73,95
 198-292	<b>TJ85</b>		
	198-406	RS232 Cable, 9P Female to 9P Female Sub.D Connector. ....	53,75
 198-700	<b>LH5000 GPS</b>		
	198-700	RS232 Cable, 25P Male to 9P Female Sub.D Connector. ....	69,10
 198-701	198-701	RS232 Cable, 25P Male to 9P Male Sub.D Connector. ....	57,66
	<b>TJ844/854</b>		
 96ET17-3	96ET17-3	RS232 Cable, 8P Souriau to 9P Female Sub.D Connector. ....	67,06
	<b>ADAPTER</b>		
 45-05630	45-05630	Null Modem Adapter, 9P Male To 9P Male Sub.D Connector. ....	11,23
	<b>FEATURES</b>		
 198-700	RS232 GPS cables connects TeeJet Rate controllers to mapping computers like: Matrix GS, Greenstar, Yara-N, IPAQ, LH665 and generic PC based terminals.		
	 198-701		
 96ET17-3			
	 45-05630		

# TeeJet TECHNOLOGIES ISOBUS SPRAYER

	PART NO.	DESCRIPTION	EURO
<b>ISO 11783 Compliant System</b>	<b>KITS</b>		
	903-318	Matrix 570VT Kit .....	Contact TeeJet
	903-210	IC18-ISOBUS Kit, TJ844 Compatible .....	
	901-456-100	TeeJet ISOBUS SwitchBbox, 9-Section .....	

**Easy to Use and Future-Proof**

IC18 offers the best combination of highly effective sprayer control and ISO 11783 (ISOBUS) system compatibility. The IC18 is fully ISOBUS compliant so connection to your tractor's built-in ISOBUS terminal, or the TeeJet Matrix 570VT terminal are all possible. In either case, this system provides proven TeeJet sprayer control compatible with tomorrow's standards.

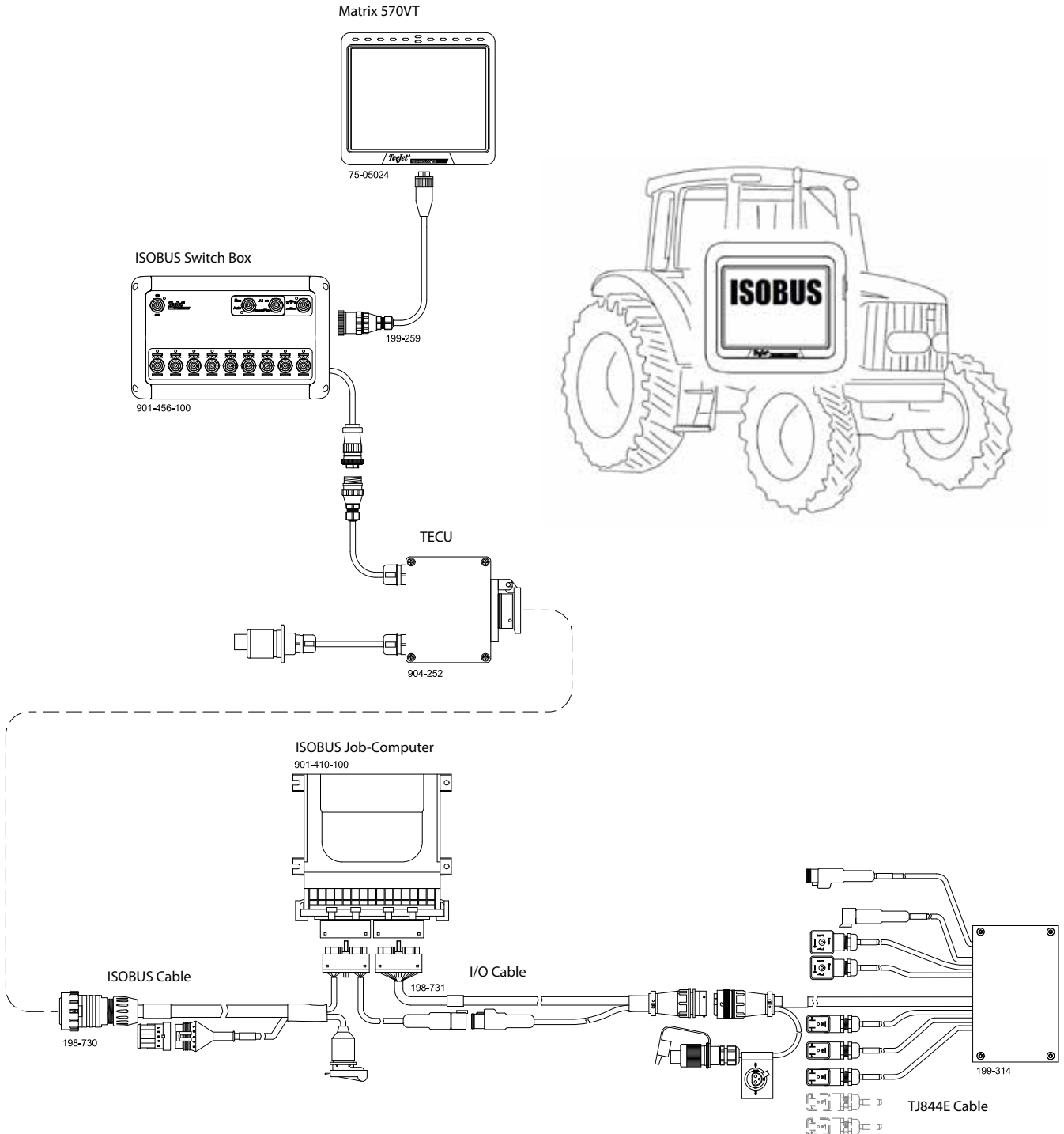

PART NO.	DESCRIPTION	EURO
005-820	Paper roll (110mm) for printer	€ 11,36
006-2104	Tube Python 1/4" Bulk / ft BLÅ	14,16
006-2105	Tube Python 3/8" Bulk / f BLÅ	17,69
006-2106	Tube Python 1/2" Bulk / ft	20,05
008-2000	Viton Bulk 3/16/ft.	27,78
008-2104	Tube ED-Plex 1/4" bulk / ft	14,16
008-2105	Tube ED-Plex 3/8" bulk / ft SORT	16,52
008-2106	Tube ED-Plex 1/2" bulk / ft SORT	16,52
00CA127	Empty housing 844 profile, 228mm	110,70
00ET055-2D	Cylindric wheel sensor with Deutsch con.	182,63
00ET095	Booster 25A	161,98
00ET135-1.5	Software programming cable TeeJet 8x4	116,57
00SP107	Spare part connector kit 28p Souriau	139,90
010-025-CZ	Installation Manual Tilt Gyro Module -CZ	8,81
010-025-D	Installation Manual Tilt Gyro Module -D	8,81
010-025-ES	Installation Manual Tilt Gyro Module -ES	8,81
010-025-F	Installation Manual Tilt Gyro Module -F	8,81
010-025-HU	Installation Manual Tilt Gyro Module -HU	8,81
010-025-PL	Installation Manual Tilt Gyro Module -PL	8,81
010-025-RU	Installation Manual Tilt Gyro Module -RU	8,81
010-025-UK	Installation Manual Tilt Gyro Module -UK	8,81
020-012-DK	LH 1000 User Guide	9,58
020-033-CZ	CL220 User Guide - CZ	19,11
020-033-D	CL220 User Guide -D	19,11
020-033-DK	CL220 User Guide -DK	19,11
020-033-E	CL220 User Guide -E	19,11
020-033-F	CL220 User Guide -F	19,11
020-033-HU	CL220 User Guide -HU	19,11
020-033-PL	CL220 User Guide -PL	19,11
020-033-RO	CL220 User Guide -RO	19,11
020-033-RU	CL220 User Guide -RU	19,11
020-033-UK	CL220 User Guide -UK	19,11
020-034-DK	CL230 BP User Guide -DK	28,07
020-034-RO	CL230 BP User Guide -RO	28,07
020-034-SF	CL230 BP User Guide -SF	28,07
020-045-UK	Installation Manual, ABSC to Berthoud	16,03
020-122-DK	LH 1200 User Guide	9,58
030-0001	K Coupler 1/2" x 5/8"	45,99
102-0108	Decal Tank Scale 100 Lt.	15,87
102-0110	Decal, Chemical Tank ID	7,93
105-0002	Console Dual Drive Agitation	192,21
105-0007	Console Chem Flow Sensor	511,81
105-0012	CONSOLE, VARIABLE SPEED, SINGLE AGITAT.	328,74
120-0014	Sensor CFM 18mm, LED	204,00
120-0030	Flow Sens Assy	370,30
120-0151	Flow Meter, 1-1/2" Mid-Tech, W/1-1/2 H.T	544,77
160-0001	Tank 28 Lt. 1/2 Fitting	313,67
160-0005	Mounting Base Single 28l tank	180,43
160-0006	Coupling Foamle 1/2" w/fitting	112,03
16-00008	Sensor, PCB Assembly	159,01
160-0015	Mounting Base Dual S/S w/bracket	389,16
160-0021	Tank 28 Lt 1/2" cw/Agitation	1054,25
16-00022	Sensor Camera Teejet	202,82
160-0025	Tank, 25 gal. 75" Fitting w/aqitation	1528,31
160-0033	Tank 100 Lt 1/2" Fittings	780,66
160-0035	Tank 100 Lt. 1/2" Fit w/agitation	1509,44
16-40007	SENSOR, WHEEL, ASBL, 38525-1	159,79
16-50016	SWITCH, PRESSURE, 290-725 #4MORB,	87,63
166-150	Sikring 16A 5x20mm Træg	0,42
166-200	Fuse 2A 5x20mm Fast	0,71
166-253	Fuse 25A circular	0,71
166-255	Fuse 8A Autotype	4,44
166-315	Fuse 3.15A 5x20mm Slow	0,71
166-403	Fuse 3A Flat mini	5,18
166-601	Fuse 630mA 5x20mm fast	0,62
166-602	Fuse 1A Flat	1,51
166-603	Fuse 3A Flat	0,50
166-632	Fuse 4A 5x20mm slow	0,71
166-635	Fuse 6.3A 5x20mm slow	0,62
168-102	Fuse holder for wire 6.3 Amp 5 x 20 mm	3,69
170-0001-KIT	Agitation Kit, 28 litre Tank	752,36
170-0007	Motor for MultiFlow tank agitation	457,56
170-0008-KIT	Agitation Kit, 100l tank	761,80

PART NO.	DESCRIPTION	EURO
175-090	Conn. SMA female/female adapter	21,49
178-208	Conn. 7p cable male, DIN 9684-1	44,70
178-419	Terminal block plug 6p. pitch 5.08	5,33
178-507	Snap for Sub D	0,71
178-509	Housing for sub. D 25.	17,03
178-511	Sub D plug 25 pol. w/terminal soldering	9,66
178-554	AMP SuperSeal 3p sealing cap f/plug	6,17
178-600	Trailer Plug (female) LH version	13,10
178-601	Trailer Plug (male) LH version	11,91
178-638	Deutsch cap for 9p receptacle	22,74
178-669	Deutsch back cap f/3p receptacle	3,68
178-700	Powell ISOBUS implement conn. (IBIC)	83,51
178-837	Power plug, cigarette lighter	27,09
197-109	Extension Cabel (2 Meters)	394,45
197-238	DIN/ISO connection cable, 2m	129,11
197-889	BoomPilot 8p Souriau to 2x2 Packard CAN	98,01
198-025	Cable for mounting bracket Version 3	48,96
198-035	Printer Cable LH 5000/ PenPlus	70,44
198-040	Flow Meter cable 4.6m	36,97
198-075	Maincable f. Hydraulic control	303,92
198-094	Controller cable Müller Spray-Contr. S	344,66
198-136	Controller cable Müller Spray-Contr. S	346,63
198-140	Connection cable for LH 1200S	28,95
198-157	Regulation Cable for Slurry Spreader	263,19
198-173	Download adaptor cable 5p AMP SS	124,58
198-174	Download adaptor cable ISO Switch Box	123,50
198-202	Download adaptor cable IC34, Cinch	99,08
198-207	Download adapter box, RS232	222,88
198-222	Power cable, Packard to Packard, 3m	38,58
198-224	Prox. sensor 5m cable AMP SS conn.	72,57
198-247	ø12mm proximity sensor, 5m cable and	81,40
198-255	Download cable PC-IC24/85	50,41
198-262	Maschine cable for TJ500 seeder kit, 6m	133,51
198-266	Download cable LH500 V2 & TJ500	78,95
198-271	Sensor 2-core 5m, 7p DIN9684-1 con.	71,73
198-276	TJ500 printer cable	57,30
198-280	LH500/TJ500 serial GPS cable, type I	40,93
198-284	LH500/TJ500 serial GPS cable, type II	43,14
198-286	LH500/TJ500 Serial GPS cable - type III	40,93
198-291	70 Series Download cable kit	156,15
198-292	Greenstar - Quantron P GPS-CABLE	90,80
198-312	Cable for sieve Sensor/Sure Seal plug	34,90
198-331	Power distributor cable, 70 junction box	75,98
198-332	Power distributor cable, Cobo to 2x Cobo	84,85
198-343	BoomPilot SDM cable, SwitchBox to Optima	319,19
198-350	Cable 3p AMP SS to loose ends, 10m	52,97
198-352	BoomPilot SDM cable, SwitchBox to Evrad	334,95
198-395	TeeJet 8 function hydr. cable	514,48
198-396	BoomPilot SDM cable TJ744E, 5 sect.	224,53
198-397	Power supply cable for SDM cable	101,16
198-398	BoomPilot SDM cable JD EL4, 9 sect. + M.	224,53
198-405	LH500/TJ500 serial data transfer cable	42,47
198-406	85 serial data transfer cable	53,75
198-408	LH6000 serial data transfer cable	73,95
198-410	BoomPilot SDM cable TJ834/TJ844/TJ854	228,85
198-415	BoomPilot SDM cable TJ844 13 S + M	252,62
198-431	PLP I/II termination for console	26,43
198-432	PLP I termination for module	18,10
198-446	Cable hydraulic, 2.5m	39,74
198-449	Download adapter cable TJ500/LH500 USB	170,49
198-450	Download adapter box, USB	343,91
198-452	Download adaptor cable IC24/LH6000/LH85	118,62
198-496	CL220/GPS speed sensor to AMP SS adaptor	106,18
198-500	Cable for LH1600 clutch, 2 wires, 3m	8,95
198-513	Matrix G speed cable to Bogballe	142,23
198-514	Matrix G speed cable to LH500/LH85	97,35
198-528	CL220/GPS speed sensor to 7p Binder	85,50
198-552	Printer Comm. Cable Alfapanel 3, 844	71,64
198-554	Pressure sensor adaptor cable 3m	47,95
198-555	Cable 2p AMP SS, 10m	34,34
198-560	71 Speed/area/distance adaptor cable	59,28
198-563	Pressure sensor adaptor cable 0.5m	49,64
198-580	Pressure sensor adaptor cable 1m	45,02

\* Subject to RTK discount

\*\* Subject to REP discount

PART NO.	DESCRIPTION	EURO
198-589	Cable hydraulic, 10m	44,02
198-593	CL220/GPS speed sensor to JST f/junct.	67,84
198-595	CL220/GPS speed sensor to Bogballe	142,23
198-599	Speed sensor TeeJet 500, 5m	116,75
198-600	CenterLine Power Cable	145,04
198-601	Power cable, battery <=> Packard	79,01
198-603	CenterLine DGPS Data Cable	145,04
198-605	Adapter Cable RX350-370 Receiver/SwathXL	145,04
198-606	Mellemkabel RX350P CenterLine/DataLink	152,13
198-608	Valve cable for TankMatic sprayer, 4.1m	19,70
198-611	71 TankMatic adaptor cable	85,92
198-615	73 EPC Sprayer adaptor cable	126,23
198-619	Speed sensor 71 Monitor	149,57
198-659	Cable JST<=>DIN for Reg. valve, 10m	39,14
198-667	Adaptor cable for 98ET42.. REG + Master	49,76
198-669	CL220/GPS speed sensor to 7p Binder	72,12
198-670	CL220/GPS speed sensor to LH500/LH85	105,97
198-675	CL220/GPS speed sensor to Framatome pins	68,53
198-677	GPS speed sensor adaptor cable, 70 S.	47,78
198-678	GPS speed sensor/implement adaptor cable	152,13
198-683	Power Cable, Cobo <=> Junction Box	133,97
198-685	TeeJet 500 DIN/ISO adaptor cable, 1.2m	107,18
198-686	CL220/GPS speed sensor to TJ500 adaptor	97,35
198-687	CL220/GPS speed sensor to Amatron +	93,41
198-688	CL220/GPS speed sensor to Sulky Vision	133,25
198-700	Connecting cable Datamodule - LH 5000	69,10
198-701	LH 5000 iPaq connection cable	57,66
198-815	Cable JST<=>DIN for Reg. valve, 1.5m	35,54
198-927	Power cable for LH 1600 1.5m	51,93
198-928	Main Cable for LH 1600	54,91
198-929	LH 1600 9 meter main cable	68,10
198-932	Power Lead 3 Pin Cobo for LH 1600	48,93
199-200	Cable mini-DIN<=>JST for 430, 1.5m	25,53
199-201	Cable mini-DIN<=>JST for 430, 3m	18,45
199-259	Matrix VT <=> 9p AMP adaptor cable, 0.5m	114,80
199-263	BoomPilot adaptor cable 8p Souriau, 1m	120,67
199-266	ISOBUS 9p AMP in-cab to Console cable	112,93
199-268	73 Spray pressure sensor adaptor cable	73,25
199-269	73 Sprayer adaptor cable, complete	181,40
199-270	Cable JST<=>Packard for Pressure sensor	24,25
199-271	Cable JST<=>Packard for Pressure sensor	25,31
199-272	Cable JST<=>Packard for Pressure sensor	32,06
199-274	Direct wiring, 8m, M, 5 S, PR, SP	420,03
199-279	Direct wiring, 9m, M, 7 S, PR, SP	566,19
199-285	Direct wiring EPC, M, 2S, PR, SP, 4.75m	412,01
199-300	Spray cable 5x Sect., SP(3m), PR(3m)	504,87
199-301	Spray cable 5x Sect., SP(3m), PR(3m)	420,01
199-302	Spray cable 5x Sect., SP(3m), FL(0.5)	468,44
199-304	Spray cable 7x Sect., SP(3m), PR(3m)	525,34
199-305	Spray cable 9x Sect., SP(3m), PR(3m)	611,55
199-310	Spray cable 5x 430(8m), M(4.5m), SP(3m)	572,99
199-311	Spray cable 7x 430, M(1m), SP(3m)	501,24
199-312	Spray cable 7x 430, M(4.5m), SP(3m)	486,44
199-313	Spray cable 5x 430, M(4.5m), SP(3m)	462,00
199-314	Spray cable 5x 430, M(4.5m), SP(3m)	449,49
199-315	Spray cable 5x 430, M(1m), SP(3m)	457,13
199-316	Spray cable 9x 430, M(1m), SP(3m)	599,83
199-317	Spray cable 5x 430, M(4.5m), SP(3m)	462,00
199-318	Spray cable 7x 430, M(4.5m), SP(3m)	486,44
199-322	Spray cable Arag Bravo 5x430, M(1m)	461,01
199-350	Spray cable 5x e-ChemSaver SP(3m)	460,73
199-351	Spray cable 9x e-ChemSaver SP(3m)	535,14
199-360	Spray cable 5x DPDT, M(1m), SP(3m)	523,87
199-361	Spray cable 4x DPDT, M(1m), SP(3m)	508,12
199-362	Spray cable 6x DPDT, M(1m), SP(3m)	569,14
199-363	Spray cable 5x DPDT, M(1m), SP(3m)	528,49
199-370	TeeJet 744E, M + 5x Arag harness, 5.5m	422,21
32-04020	Foot switch, engage/disengage	208,52
32-04040	Switch, engage/disengage, FieldPilot	48,82
32-50009	Switch, Boom, CP2621 1-Commat	23,92
35-01005	Valve, Check Hyd. #6Forb, 5PSI	86,66
35-02152	Valve, FieldPilot, OC, HF, #12P & EF	1602,87
35-02153	Valve, FieldPilot, OC, #8P & EF ports	1540,40

PART NO.	DESCRIPTION	EURO
35-02155	Valve, counter balance 0-20GPM, 5000PSI	601,07
35-02172	Valve, FieldPilot, PC, LS	2498,70
35-02180	Valve, FieldPilot, PWM, CC, 8 l/min	2033,18
35-02183	Valve, FieldPilot, PWM, OC, 4 l/min	2553,53
35-02185	Valve, FieldPilot, PWM, OC, 8 l/min	2577,58
35-02186	Valve, FieldPilot, PWM, CC, X l/min	2531,51
35-02189	Valve, FieldPilot, PWM, OC	2577,58
35-02193	VALVE, FLDPLT, PWM, 2.1 GPM,	2230,17
401-0016	Cable Pwr 1 Lead 2' w/Pkrd Con.	53,07
402-0009	Cable 18' Ag Pwr. TASC F5w Ex	89,62
404-0003	Chemical flow cable, 25', sens. assembl.	93,15
404-0022	Cable F1 Contr 20' PWR Cable	160,38
404-0068	Cable Rem Prime 1-3	82,55
404-0069	Cable Rem Prime 4-6	88,44
405-0038	Interface Cable TASC 9BS	356,14
405-0044	Int Cable FI Meter 12'/16	312,49
405-0056	Interface, Cable, Mid-Tech Flow Meter	315,66
405-0081	Interface Rem Prime Pump Mt	241,74
405-0082	Switchbox Rem Prime 6 pos.	257,07
405-0143	Cable Valve Dr TASC/ARC	327,83
45-05080	FP Harness for DauerDanfoss Autosteer	98,74
45-05279	Power cable US lighter plug <=> Packard	78,96
45-05301	Cable assy, Signal, Pump to TASC	93,15
45-05322	Ground speed cable, Tasc, 3 pumps	192,21
45-05340	Cable, Deutsch to DB9	145,04
45-05348	Cable, Pressure Sensor to L6K	42,46
45-05350	RX350P GPS-/Powerkabel 2 udgang & Strøm	206,37
45-05381	Cable 3 Pos. Battery 12' w/15A fuse	134,43
45-05427	Harness Centerline to Smartpad II	204,00
45-05458	CL220 Power cable, Lighter plug	67,21
45-05459	Cable, Centerline 220 GPS Simulator	84,90
45-05476	Centerline 220 rev 1 cable, GPS,	108,49
45-05478	CL220 Battery Power Cable	84,90
45-05495	Cable, RX370p, speed only	136,79
45-05510	CL220/GPS speed sensor to PowerLink 640	62,10
45-05576	SmartCable for Raven 440/450/460	673,60
45-05588	BoomPilot GPS interface cable for	57,75
45-05605	Cable, GPS Splitter CL, Classic to DB9	157,93
45-05613*	NMEA cable f. RX-600RTK	41,68
45-05615	Cable, Matrix SPD out/sense, 4p ConXall	42,37
45-05617	Camera cable extension 6.1m	104,56
45-05618	Camera cable extension 18m	137,58
45-05622	CABLE, SMART, SINGLE, SECTION, BOOMPILLOT	344,72
45-05624	Power cable EU lighter plug <=> Matrix	59,44
45-05625	Power cable Cobo <=> Matrix 1.35m	55,03
45-05626	Power/CAN/Data cable Matrix 1.35m	126,58
45-05630*	Null modem adaptor, male-male 9p Sub-D	11,23
45-05642*	RTK JD 30-Series direct steer cable	96,55
45-05643*	RTK Challenger MT Series cable	47,15
45-05644*	RTK JD Starfire Emulation cables	123,49
45-05645	CABLE POWER ADAPTER, LIGHTER US TO CXA	64,73
45-05647	Power cable, EU lighter plug <=> Packard	61,35
45-05648	Power cable, Cobo <=> Packard	55,42
45-05650	CL220 Power cable, Cobo	60,66
45-05664	CL220 Power cable, EU lighter plug	67,01
45-05676	Cable, Patch antenna extension 7.5m	174,01
45-05678	Cable, RXA-25 Antenna, 6.5m	126,58
45-05699*	Direct CAN steer cable for FENDT 6xx,	56,13
45-05701*	Direct CAN Steer cable, FENDT 928, 936	137,58
45-05705*	Cable, EZ-Steer+ to RX-600RTK	137,58
45-05706*	Cable, EZ-Steer 500 to RX600RTK	137,58
45-05707*	Cable, John Deere ATU to RX-600RTK	137,58
45-05734	Cable RXA-25 Antenna, 9m	187,11
45-05765	Cable, Matrix SPD out/sense, 8p ConXall	72,83
45-05774	BoomPilot SDM cable TJ834/TJ844/TJ854	224,53
45-05775	Cable, Power Matrix, Battery 10ft., 10A	71,28
45-05782	Cable, Trimble AS Valve	136,91
45-05786	Cable, RXA-30 Antenna, 6m	122,21
45-05787	Cable, RXA-30 Antenna 9m	193,76
45-05789	TeeJet 744E Power cable, Cobo, 1m	63,00
45-05810	Steering wheel adapter cable ext.	209,98
45-05822	CABLE,PSI SWITCH, 15', FLDPLT,	36,87
45-05826	Power/CAN/Data cable Matrix 3.6m	138,92

\* Subject to RTK discount

\*\* Subject to REP discount



PART NO.	DESCRIPTION	EURO
45-05838	Cable w/8P con. Matrix 570 & 840	34,17
45-05845	Power/CAN/Data cable Matrix 2.85m	128,23
45-05851	CABLE, PRESS. SWITCH ADAPTOR, 2.4M	38,14
45-05867	Power cable Cobo <=> Matrix 2.35m	85,57
45-06505	Harness DCM Sensor	227,59
45-07500	Harness, DCM power/speed	136,79
45-07703	Cable SCM FieldPilot II (Valve Harness)	97,46
45-07704	CABLE, SCM TO POWER, FP VALVE & MASTER	164,56
45-07708	Cable, SCM harness, CAN	300,43
45-07716	HARNESS, TGM/AGM, CAN TEE	117,33
45-07718	Harness, SCM short	244,66
45-08101	CAN Termination male 4p WP	8,15
45-08102	CAN Termination female 4p WP	21,48
45-08106	Cable, CAN ext. 6 feed, WP	79,01
45-08112	Cable, CAN ext. 12 feed, WP	93,15
45-10101	Harness relay interf. SM5 to Spra-Coupe	417,04
45-10103	Harness, Steering (valve A and B)	99,92
45-10133	TeeJet 744E, 3x430 harness, 5.5m	233,45
45-10136	HARNESS, FLDPLT VALVE, A, B, & MASTER	144,26
45-20042	CL220/GPS speed sensor to TJ834/TJ844	55,53
45-20240	CABLE, MAIN, EXT., 4 METER, 48297-55-4	220,98
50-01067	Packard 3p MP 150 P25 female conn.	11,92
50-05001	Packard cavity plug MP 150 P25	0,11
50-10000	Packard MP150 female crimp, 0.80-1.00mm2	1,44
51-20008	Pressure Gauge, Liquid, 100PSI/7Bar	48,30
54-02017	Pump piston, assembly	4129,75
54-02020	PUMP HEAD, PISTON	1069,84
54-02044	Mixing Chamber, 2" Female NPT	213,44
570-001	Pressure sensor 10 bar 1/4 NPT, WIKA	180,37
570-002	Pressure sensor 25 bar 1/4 NPT, WIKA	208,37
570-010	Pressure sensor 10 bar 1/4 BSP, Keller	192,65
570-011	Pressure sensor 25 bar 1/4 BSP, Keller	198,48
570-012	Pressure sensor 60 bar 1/4 BSP, Keller	210,16
570-020	Pressure Sensor TankMatic, 0-0.40bar	602,47
570-112	Inductive sensor, d12mm, 5m cable	87,97
570-128	Induktiv føler 12mm, 2m cable	78,04
570-575	Relay Assembly-Moisture Sensor	222,40
570-576	Wiper Motor Assembly-RH, exterior	325,27
570-577	Wiper Motor Assembly-LH, interior	325,27
57-10096	Flow Meter, std. with 3/4" hose barbs	565,57
57-10097	Flow Meter, std. with 2" hose barbs	856,13
571-010	Pressure sensor 10 bar 1/4 BSP, Keller	239,58
571-012	Pressure sensor 60 bar 1/4 BSP, Keller	239,58
588-150	Switch ON-ON double silver	23,69
588-151	Switch ON-ON double silver/gold	32,64
588-160	Omsk. 631 ON-OFF, d11.9, spader	13,04
588-164	Omsk. 638 ON-OFF-MOM, d11.9, spader	15,81
588-165	Toggle switch D: 11,9 mm MOM-OFF-MOM	14,35
588-501	Linak end-stop relay	233,88
600-0020	Propellor 5/5 11 x 2" x 30 Deg	116,19
600-0028	Motor Met 12V 1400RPM	425,72
600-0030	Propellor 5/16" x 3" Diam	104,19
60-04131	Screw Socket Head Cap, 10-24 x 1.5"SST	1,71
60-07027	Nut, Nylock 3/8-16, SST	2,24
60-10081	Velcro 1" x 3" set, 3M adhesive	4,49
64-03050	CL2x0/TJ500 rubber bumper	14,16
64-05066	Suction cup for CenterLine	93,15
64-05105	Fitting Block, QJ to 3/4", FPT	14,46
64-05112	Suction cup, CenterLine 220	55,42
64-05136	DUSTCAP MATRIX 570G & 840G,	9,08
65-05052	CenterLine Lightbar mounting bracket	28,30
65-05125	RAM mount, RAM-B-238U	17,69
65-05128	Arm double socket, 3??L, CenterLine 220	25,94
65-05179	Plate, Mounting for patch antenna	7,86
65-05185	RAM mount for camera	38,52
65-05226	Kit, Bracket for RXA-30 Antenna	105,55
65-05230	1.5" ball for RAM mount	17,10
65-05231	Spare part Slotted Disk, 360 f/sensor	43,15
68-02071	Hydr. adapter #6 run Tee ORFF	12,22
68-02073	Hydr. adapter #6 male ORFF x #6 male ORB	3,33
68-02074	Hydr. adapter #6 male ORFF x #6 male ORB	6,67
68-02075	Hydr. adapter #6 male ORFF x #8 male ORB	16,67
68-02082	Hydr. adapter #6 Male JIC x #1 Male ORB	8,87

PART NO.	DESCRIPTION	EURO
68-02118	Hydr. adapter 14 MORB x #6 MORFF	13,33
68-02122	Hydr. adapter #8maleJIC, 12 male ORB	8,87
68-02154	Hydr. adapter, #4MORB x G1/4-19 MBSPP	13,12
68-02155	Hydr. adapter #6MORB X G, 3/8-19 MBSPPP	11,01
68-02156	Hydr. adapter #8MORB X G, 1/2-14 MBSPPP	14,31
68-02157	Hydr. adapter #12MORB XG, 3/4 - 14 MBSPP	19,40
68-02169	Hydr. adapter #8morb x, 12 I	58,88
68-02170	Hydr. adapter #8morb x, 15 I	62,22
68-02171	Hydr. adapter #12morb x, #8forb	6,67
70-04008	Tube Assy, QD 3/16" Python	40,61
70-04009	TUBE ASSY, QD 1/4" Python	40,09
70-04012	TUBE ASSY, QD 5/8", PYTHON	37,40
70-04013	Tube Kit QD Python	155,25
75-30005	Display SmartPad II	2910,39
75-30032	Console Centerline 220	948,01
75-30034	CONSOLE, CENTERLINE 220, AUTONOMOUS	948,01
75-30034-OMB	CONSOLE, CENTERLINE 220, AUTONOMOUS	974,08
75-30068-DEMO	Matrix 570VT DEMO	1664,00
75-30082	Console, Matrix Pro 570G, ClearPath	1664,00
75-30083	Console Matrix Pro 570G ClrPath/Glonass	1872,00
75-30084	Console, Matrix Pro 840G Clearpath	2496,00
75-30090	Console Matrix 840G ClearPath/Glonass	2704,00
75-50060	TeeJet 744E-3 Console, 100PSI/7Bar	193,61
75-50061	TeeJet 744E-5 Console, 100PSI/7Bar	223,97
76-01016	Guidance simulator steering wheel	358,50
775-803	Magnet	2,99
78-00044	Switch, Matrix 570G, Work on/off	104,56
78-00046	Switchbox, WORK ON-OFF w/8p connector	104,56
78-05050	Interface, SMARTPAD II, Assembly	334,90
78-05072	BoomPilot SDM (Section Driver Module)	729,74
78-05082	SmartCable Bogballe Calibrator,	544,99
78-05090	SmartCable, Rauch Quantron E	544,99
78-08019	PUMP CONTROL ASSY	339,97
78-08020	PRIME MODULE FOR MT500	220,98
78-08025	DCM, Dual contr. module	995,28
78-08027	SFM 10 OPutput WP	1853,80
78-08035	SFM, Booms 11-20 Series	1044,82
78-08051	Steering Control Module (SCM)	2638,28
78-08061	Steering Control Module, CAN	2638,28
78-08067	Video Selector Module, 4 channel video	440,26
78-08068	Video selector module for Matrix 840G	522,81
78-08072	Interface FieldPilot, constant voltage	152,43
78-08075	Steering Control Module, PRO (SCM)	2638,28
78-08075-OMB	Steering Control Module, PRO (SCM)	2638,28
78-08077	TILT GYRO MODULE	587,73
78-08077-OMB	TILT GYRO MODULE	587,73
78-50049	ATA Flash Datacard (20Mb) for Smartpad	200,46
78-50058	Swath XL Lightbar	1419,82
78-50082	Radar Compact II incl. 0.4m cable	600,24
78-50106	POWER SUPPLY, CenterLine Display	146,19
78-50107	CenterLine Wireles 433	599,07
78-50140	Lightbar, CAN, gen. II CAN	1779,50
78-50148	Receiver, GPS RX370P EGNOS	2147,41
78-50151	Kit, Receiver, GPS RX500	8016,69
78-50155	Patch antenna, 5m cable	150,95
78-50179	Magnetic mount for camera	38,52
78-50187	Antenna, RXA-30 w/o bracket	327,75
78-50190	Antenna, GPS Patch L1 w/GLONASS	192,35
796-0002	Magnet Calibration	9,94
807-720	Matrix Support Package	137,58
814-334	Screw M3x35 f/mini DIN conn. SS	1,21
822-0001	Nipple reducing PP 3/4" x 1/2"	5,89
835-0001	Fitting BLKHD 3/4"	16,52
841-521	Mounting Bracket for Sieve Sensor	8,95
842-137	Flange for hoseconnection, D40 Flow Meter	25,96
842-141	Flange 2" hoseconnection, D40 Flow Meter	19,07
842-516	Bracket for speed and override sensors	8,08
842-521	Mounting plate for trailer plug	13,33
843-102	Mounting Bracket for LH 1000	27,66
843-122	Mounting Bracket for LH 1200	23,69
843-152	Mounting Bracket for LH 1600	25,25
844-044	Bracket for TeeJet 500 monitor	4,40
844-045	Wall bracket for LH 500	4,82

\* Subject to RTK discount  
 \*\* Subject to REP discount

PART NO.	DESCRIPTION	EURO
856-113	Møtrik PG9 sort m/30% glasf.	0,71
856-133	O-ring ø10x1,5mm Perbunan, PG7	0,14
860-412	Seal for DIN conn.	0,56
860-413	Seal for mini-DIN connector, NBR	0,82
860-992	Cap for switch	8,51
861-013	Flow 10D/16D/20D insert o-ring	0,71
861-014	Flow 10D/16D/20D inlet o-ring	0,71
861-022	Flow 26D insert + inlet o-ring	0,71
861-600	Trailer socket seal	9,66
861-707	Forskruning PG7, grå	2,28
861-736	Forskruning PG16, grå ø10-ø14mm	3,10
864-986	Flow 20Dx1" Hose connector	19,30
864-989	Flow 40Dx2" Hose connector	34,90
864-991	Flow 26Dx1.25" Hose connector	28,95
864-992	Flow 26Dx1.5" Hose connector	27,92
864-996	Flow 26Dx1.5" BSPT connector, male	48,96
864-997	Flow 20Dx1" BSPT connector, female	41,57
865-900	Flow 16Dx0.75" Hose connector	23,00
865-910	Flow 16Dx1" Hose connector	23,00
865-915	Flow 10Dx3/4" BSPT connector, male	19,53
865-916	Flow 10Dx3/4" BSPT connector, female	27,75
865-920	Flow 16Dx3/4" BSPT connector, male	29,58
865-983	Flow 20Dx0.75" BSPT connector, male	38,59
865-984	Flow 20Dx1" BSPT connector, male	29,65
865-985	Flow 16Dx3/4" BSPT connector, female	37,02
865-986	Connector - male for 902-986	40,01
865-987	Connector - female for 902-986	37,02
865-989	Hose connection for Hardi EC arm	12,62
876-986	Flow 10/16/20D Clip for top/26D in-line	3,69
877-986	Flow 10/16/20D Steel Clip for in-line	3,69
884-153	Clutch with pipe and seed roll	356,57
89-04000	Lubricating Grease f. Ed & Python	38,91
89VM60S.01	Hall effect sensor, shielded cable	75,11
89VM61.01	Magnet 4 pcs. for hall sensor	43,83
900-013	Print for junctionbox 2 (LH865)	37,02
900-017	Print for junctionbox 1 (LH 865)	50,36
900-100	LH 1000 Multi Plug, Monitor Part	38,59
900-101	LH 1000 Multi Plug, Tractor Part	26,71
900-103	LH 1000 Additional Mounting kit	236,52
900-120	LH 1200 Multi Plug, Tractor Part	43,47
900-121	LH 1200 Multi Plug, Monitor Part	50,75
900-123	LH 1200 Additional Mounting kit	213,55
900-158	Junction box print LH 4000	91,23
900-164	Mounted PCB f. Hydraulic control.	191,97
900-180	LH 5000 Mounting set, Version 2	441,12
900-181	LH 5000 Mounting set from ver.3+	437,43
900-188	Mounting kit for LH 5000	564,98
90-02061	Fieldware tools software	147,40
90-02157	Console kit, TASC 6300 CE, SFTWR M-3.23,	3837,18
90-02158	CONSOLE KIT TASC 6600 CE, SFTWR M-3.23,	4665,57
90-02168	Compact II Radar kit c/w cable	721,80
90-02176	801 Flow Meter + Interface	561,74
90-02177	Kit, 801 Flow Meter and interface w/ 1-	532,63
90-02211	Driver Module 40A TASC/CCI I	830,19
90-02252	Kit, repair, 801 Flow Meter	230,18
90-02331	Tilt sensor and cable for GUI	708,73
90-02349	RAM mount kit w/suction cup	100,24
90-02371-F	GPS Speed Sensor w/4p AMP CPC -F	487,04
90-02371-UK	GPS Speed Sensor w/4p AMP CPC -UK	487,04
90-02386-F	GPS Speed Sensor w/Deutsch -F	487,04
90-02386-UK	GPS Speed Sensor w/Deutsch -UK	487,04
90-02402-CZ	CenterLine 220 EGNOS rev 1, CZ manual	1065,84
90-02402-D	CenterLine 220 EGNOS rev 1, D manual	1065,84
90-02402-DK	CenterLine 220 EGNOS rev 1, DK manual	1065,84
90-02402-E	CenterLine 220 EGNOS rev 1, E manual	1065,84
90-02402-F	CenterLine 220 EGNOS rev 1, F manual	1065,84
90-02402-HU	CenterLine 220 EGNOS rev 1, HU manual	1065,84
90-02402-NL	Centerline 220 EGNOS Rev. 1	1065,84
90-02402-PL	CenterLine 220 EGNOS rev 1, PL manual	1065,84
90-02402-RO	CenterLine 220 EGNOS rev 1, RO manual	1065,85
90-02402-RU	CenterLine 220 rev 1, RU manual	1065,84
90-02402-SE	Centerline 220 EGNOS rev 1, UK manual	1065,84
90-02402-UK	CenterLine 220 EGNOS rev 1, UK manual	1065,84

\* Subject to RTK discount

\*\* Subject to REP discount

PART NO.	DESCRIPTION	EURO
90-02472	Patch Antenna, ext. cable 10"	120,29
90-02473	Patch Antenna, ext. cable 6"	96,46
90-02478-D	BoomPilot Metric Console, RAM mount kit	1117,06
90-02534*	RTK RX-600RTK GPS Rover Kit, EU	8574,13
90-02534-E*	RTK RX-600RTK GPS Rover Kit, EU	8574,13
90-02534-UK*	RTK RX-600RTK GPS Rover Kit, EU	8574,13
90-02535*	RTK PBS-601 Base Station Kit, EU	5712,42
90-02536-CZ	Tilt Gyro Module kit, CL230 & Matrix -CZ	897,01
90-02536-D	Tilt Gyro Module kit, CL230 & Matrix -D	897,01
90-02536-ES	Tilt Gyro Module kit, CL230 & Matrix -ES	897,01
90-02536-F	Tilt Gyro Module kit, CL230 & Matrix -F	897,01
90-02536-HU	Tilt Gyro Module kit, CL230 & Matrix -HU	897,01
90-02536-PL	Tilt Gyro Module kit, CL230 & Matrix -PL	897,01
90-02536-RU	Tilt Gyro Module kit, CL230 & Matrix -RU	897,01
90-02536-UK	Tilt Gyro Module kit, CL230 & Matrix -UK	897,01
90-02546	Kit, RealView Camera w/mount & 6.5m	330,20
90-02552-RU	CenterLine 220 Autonomous rev 1, w/Cobo	1065,84
90-02552-UK	CenterLine 220 Autonomous rev 1, w/Cobo	1065,84
90-02555-CZ	Kit, Matrix Pro 570G w/ClearPath,	2195,00
90-02555-D	Kit, Matrix Pro 570G w/ClearPath,	2195,00
90-02555-DK	Kit, Matrix Pro 570G w/ClearPath,	2195,00
90-02555-E	Kit, Matrix Pro 570G w/ClearPath,	2195,00
90-02555-F	Kit, Matrix Pro 570G w/ClearPath,	2195,00
90-02555-HU	Kit, Matrix Pro 570G w/ClearPath,	2195,00
90-02555-I	Kit, Matrix Pro 570G w/ClearPath,	2195,00
90-02555-NL	Kit, Matrix Pro 570G w/ClearPath,	2195,00
90-02555-PL	Kit, Matrix Pro 570G w/ClearPath,	2195,00
90-02555-PT	Kit, Matrix Pro 570G w/ClearPath,	2195,00
90-02555-RU	Kit, Matrix Pro 570G w/ClearPath,	2195,00
90-02555-S	Kit, Matrix Pro 570G w/ClearPath,	2195,00
90-02555-SF	Kit, Matrix Pro 570G w/ClearPath,	2195,00
90-02555-UK	Kit, Matrix Pro 570G w/ClearPath,	2195,00
90-02557-CZ	Kit, Matrix Pro 570G w/ClearPath/GLONASS	2395,00
90-02557-D	Kit, Matrix Pro 570G w/ClearPath/GLONASS	2395,00
90-02557-DK	Kit, Matrix Pro 570G w/ClearPath/GLONASS	2395,00
90-02557-E	Kit, Matrix Pro 570G w/ClearPath/GLONASS	2395,00
90-02557-F	Kit, Matrix Pro 570G w/ClearPath/GLONASS	2395,00
90-02557-HU	Kit, Matrix Pro 570G w/ClearPath/GLONASS	2395,00
90-02557-I	Kit, Matrix Pro 570G w/ClearPath/GLONASS	2395,00
90-02557-NL	Kit, Matrix Pro 570G w/ClearPath/GLONASS	2395,00
90-02557-PL	Kit, Matrix Pro 570G w/ClearPath/GLONASS	2395,00
90-02557-PT	Kit, Matrix Pro 570G w/ClearPath/GLONASS	2395,00
90-02557-RU	Kit, Matrix Pro 570G w/ClearPath/GLONASS	2395,00
90-02557-SF	Kit, Matrix Pro 570G w/ClearPath/GLONASS	2395,00
90-02557-UK	Kit, Matrix Pro 570G w/ClearPath/GLONASS	2395,00
90-02563	CL230BP ClearPath metric kit	2131,86
90-02565	Video selector module w/4 cameras	1628,97
90-02572	KIT, HARNESS/SDM 15 SECTIONS	1148,75
90-02588-E*	RTK RX-600Glide GPS Rover Kit, EU	7693,60
90-02588-UK*	RTK RX-600Glide GPS Rover Kit, EU	7693,60
90-02608-CZ	Kit, Matrix Pro 570G, No receiver, COBO	1695,00
90-02608-D	Kit, Matrix Pro 570G, No receiver, COBO	1695,00
90-02608-DK	Kit, Matrix Pro 570G, No receiver, COBO	1695,00
90-02608-E	Kit, Matrix Pro 570G, No receiver, COBO	1695,00
90-02608-F	Kit, Matrix Pro 570G, No receiver, COBO	1695,00
90-02608-HU	Kit, Matrix Pro 570G, No receiver, COBO	1695,00
90-02608-I	Kit, Matrix Pro 570G, No receiver, COBO	1695,00
90-02608-NL	Kit, Matrix Pro 570G, No receiver, COBO	1695,00
90-02608-PL	Kit, Matrix Pro 570G, No receiver, COBO	1695,00
90-02608-PT	Kit, Matrix Pro 570G, No receiver, COBO	1695,00
90-02608-RU	Kit, Matrix Pro 570G, No receiver, COBO	1695,00
90-02608-SF	Kit, Matrix Pro 570G, No receiver, COBO	1695,00
90-02608-UK	Kit, Matrix Pro 570G, No receiver, COBO	1695,00
90-02609-CZ	Kit, Matrix Pro 570G, No Receiver,	1895,00
90-02609-D	Kit, Matrix Pro 570G, No Receiver,	1895,00
90-02609-DEMO	Matrix 570G Demo kit	1872,00
90-02609-DK	Kit, Matrix Pro 570G, No Receiver,	1895,00
90-02609-E	Kit, Matrix Pro 570G, No Receiver,	1895,00
90-02609-F	Kit, Matrix Pro 570G, No Receiver,	1895,00
90-02609-HU	Kit, Matrix Pro 570G, No Receiver,	1895,00
90-02609-I	Kit, Matrix Pro 570G, No Receiver,	1895,00
90-02609-NL	Kit, Matrix Pro 570G, No Receiver,	1895,00
90-02609-PL	Kit, Matrix Pro 570G, No Receiver,	1895,00



PART NO.	DESCRIPTION	EURO
90-02637-PT	Matrix Pro 840G, w/ClearPath,	2995,00
90-02637-RU	Matrix Pro 840G, w/ClearPath,	2995,00
90-02637-S	Matrix Pro 840G, w/ClearPath,	2995,00
90-02637-SF	Matrix Pro 840G, w/ClearPath,	2995,00
90-02637-UK	Matrix Pro 840G, w/ClearPath,	2995,00
90-02638-CZ	Matrix Pro 840G w/ClearPath, RXA-30	3195,00
90-02638-D	Matrix Pro 840G w/ClearPath, RXA-30	3195,00
90-02638-DK	Matrix Pro 840G w/ClearPath, RXA-30	3195,00
90-02638-E	Matrix Pro 840G w/ClearPath, RXA-30	3195,00
90-02638-F	Matrix Pro 840G w/ClearPath, RXA-30	3195,00
90-02638-HU	Matrix Pro 840G w/ClearPath, RXA-30	3195,00
90-02638-I	Matrix Pro 840G w/ClearPath, RXA-30	3195,00
90-02638-NL	Matrix Pro 840G w/ClearPath, RXA-30	3195,00
90-02638-PL	Matrix Pro 840G w/ClearPath, RXA-30	3195,00
90-02638-PT	Matrix Pro 840G w/ClearPath, RXA-30	3195,00
90-02638-RU	Matrix Pro 840G w/ClearPath, RXA-30	3195,00
90-02638-SF	Matrix Pro 840G w/ClearPath, RXA-30	3195,00
90-02638-UK	Matrix Pro 840G w/ClearPath, RXA-30	3195,00
90-02639-CZ	Matrix Pro 840G w/ClearPath/GLONASS,	2995,00
90-02639-D	Matrix Pro 840G w/ClearPath/GLONASS,	2995,00
90-02639-DK	Matrix Pro 840G w/ClearPath/GLONASS,	2995,00
90-02639-E	Matrix Pro 840G w/ClearPath/GLONASS,	2995,00
90-02639-F	Matrix Pro 840G w/ClearPath/GLONASS,	2995,00
90-02639-HU	Matrix Pro 840G w/ClearPath/GLONASS,	2995,00
90-02639-I	Matrix Pro 840G w/ClearPath/GLONASS,	2995,00
90-02639-NL	Matrix Pro 840G w/ClearPath/GLONASS,	2995,00
90-02639-PL	Matrix Pro 840G w/ClearPath/GLONASS,	2995,00
90-02639-PT	Matrix Pro 840G w/ClearPath/GLONASS,	2995,00
90-02639-RU	Matrix Pro 840G w/ClearPath/GLONASS,	2995,00
90-02639-SF	Matrix Pro 840G w/ClearPath/GLONASS,	2995,00
90-02639-UK	Matrix Pro 840G w/ClearPath/GLONASS,	2995,00
90-02640-CZ	Matrix Pro 840G w/ClearPath/GLONASS,	3195,00
90-02640-D	Matrix Pro 840G w/ClearPath/GLONASS,	3195,00
90-02640-DK	Matrix Pro 840G w/ClearPath/GLONASS,	3195,00
90-02640-E	Matrix Pro 840G w/ClearPath/GLONASS,	3195,00
90-02640-F	Matrix Pro 840G w/ClearPath/GLONASS,	3195,00
90-02640-HU	Matrix Pro 840G w/ClearPath/GLONASS,	3195,00
90-02640-I	Matrix Pro 840G w/ClearPath/GLONASS,	3195,00
90-02640-NL	Matrix Pro 840G w/ClearPath/GLONASS,	3195,00
90-02640-PL	Matrix Pro 840G w/ClearPath/GLONASS,	3195,00
90-02640-PT	Matrix Pro 840G w/ClearPath/GLONASS,	3195,00
90-02640-RU	Matrix Pro 840G w/ClearPath/GLONASS,	3195,00
90-02640-SF	Matrix Pro 840G w/ClearPath/GLONASS,	3195,00
90-02640-UK	Matrix Pro 840G w/ClearPath/GLONASS,	3195,00
90-02641-CZ	Matrix Pro 840G w/ClearPath/GLONASS,	3195,00
90-02641-D	Matrix Pro 840G w/ClearPath/GLONASS,	3195,00
90-02641-DK	Matrix Pro 840G w/ClearPath/GLONASS,	3195,00
90-02641-E	Matrix Pro 840G w/ClearPath/GLONASS,	3195,00
90-02641-F	Matrix Pro 840G w/ClearPath/GLONASS,	3195,00
90-02641-HU	Matrix Pro 840G w/ClearPath/GLONASS,	3195,00
90-02641-I	Matrix Pro 840G w/ClearPath/GLONASS,	3195,00
90-02641-NL	Matrix Pro 840G w/ClearPath/GLONASS,	3195,00
90-02641-PL	Matrix Pro 840G w/ClearPath/GLONASS,	3195,00
90-02641-PT	Matrix Pro 840G w/ClearPath/GLONASS,	3195,00
90-02641-RU	Matrix Pro 840G w/ClearPath/GLONASS,	3195,00
90-02641-SF	Matrix Pro 840G w/ClearPath/GLONASS,	3195,00
90-02641-UK	Matrix Pro 840G w/ClearPath/GLONASS,	3195,00
90-02642-CZ	Matrix Pro 840G w/ClearPath/GLONASS,	3395,00
90-02642-D	Matrix Pro 840G w/ClearPath/GLONASS,	3395,00
90-02642-DK	Matrix Pro 840G w/ClearPath/GLONASS,	3395,00
90-02642-E	Matrix Pro 840G w/ClearPath/GLONASS,	3395,00
90-02642-F	Matrix Pro 840G w/ClearPath/GLONASS,	3395,00
90-02642-HU	Matrix Pro 840G w/ClearPath/GLONASS,	3395,00
90-02642-I	Matrix Pro 840G w/ClearPath/GLONASS,	3395,00
90-02642-NL	Matrix Pro 840G w/ClearPath/GLONASS,	3395,00
90-02642-PL	Matrix Pro 840G w/ClearPath/GLONASS,	3395,00
90-02642-PT	Matrix Pro 840G w/ClearPath/GLONASS,	3395,00
90-02642-RU	Matrix Pro 840G w/ClearPath/GLONASS,	3395,00
90-02642-SF	Matrix Pro 840G w/ClearPath/GLONASS,	3395,00
90-02642-UK	Matrix Pro 840G w/ClearPath/GLONASS,	3395,00
90-02661	Kit, Real View Camera, w/Mount, no cable	225,64
90-02662-D	CenterLine 220 Egnos w. RXA-30 Antenna	1370,32
90-02662-DK	CenterLine 220 Egnos w. RXA-30	1333,64

PART NO.	DESCRIPTION	EURO
90-02662-HU	CL220 Egnos with RXA-30	1333,64
90-02662-PL	CL220 Egnos with RXA-30	1333,64
90-02662-RU	CL220 Egnos with RXA-30	1333,64
90-02662-UK	CL220 Egnos with RXA-30	1333,64
90-02700	KIT, RAM MOUNT w/4.5" SUCT. CUP MATR840	104,11
90-02703*	Kit RX510 GPS L1/L2 Clearpath GPS+Glonas	5693,50
90-02720	KIT, RXA-30 Antenna, 6m cable	439,16
90-02721	KIT, RXA-30 Antenna 9m cable	456,77
90-02725	Suction Cup Upgrade for Matrix 570G	106,86
90-02744*	Mounting plate(Quick.) RX510/RX610	427,44
90-02747*	Kit, RX510 L1/L2 Clearpath GPS+GLO+EGNOS	3200,46
90-02748	Mounting plate kit for GPS antenna	19,23
90-02757	KIT: TILT GYRO MODULE FOR MATRIX PRO	897,01
90-02793*	Kit GPS Receiver RX610 RTK, GPRS HSPA,EU	8142,94
900-297	Print Junctionbox, standard for LH 1200S	51,22
900-300	Print for LH 5000 Conn. box	95,04
900-302	Connection Print for Slurry	117,19
900-303	Print for Junctionbox LH 5000 Version 3.	69,67
900-369	RS232 module for PIC	67,25
900-496	PCB for LH 1600	49,65
900-500	LH 1600 Print for junctionbox	128,28
90-06023	MT500 Pump Tasc w. calibration valve	3659,21
90-06027	MT600 Pump kit 0.03 - 3.0 l/min.	4150,97
90-06050	MT600 Pump kit 0.06 - 6.0 l/min.	5345,51
90-06053	KIT, PUMP TASC, REMOTE, REVERSE PRIME	3739,72
900-624	Thumb Screw, 1000 series	2,42
900-708	Light sensor, 8 meters, new version	37,02
900-753	Supply cable 4 Meters	6,68
900-982	Sensor, 2-core, 5 meter, standard	45,27
900-983	Sensor, 3-core, 5 meter, standard	70,38
900-984	Sensor, 3-core, bipolar	70,38
900-995	Module Interface Auto Sections	1466,39
901-102	LH 1000 Head Only	477,43
901-119	2 core sensor with Binder plug	75,91
901-122	LH 1200 Head Only	725,75
901-288	Hydraulic switch box, 8 function, SPST	542,61
901-340	Simulator, Speed	97,01
901-341	Simulator, Flow	128,92
901-496	Extension Cable for LH 1600, 2m	49,65
901-750	Sievesensor cable 5 meters	18,59
901-759	Straw Walker Sensor Cable 2,3 meter	20,01
901-765	LH 765 Head and Mountingbracket	885,22
901-982	Sensor, 2-core, 10 meter	59,31
901-983	Sensor 3-core, 10 meter	81,59
901-985	Alu flow insert	448,49
901-986	Flow Meter Insert, 16D-20D	203,88
902-030	AMP SuperSeal 3p sealing plug f/recept.	6,17
902-100	Controller cable Müller Spraydos 7 Sect.	207,02
902-159	LH 4000 Trailer cable Trailerpart	151,25
902-206	Parking plug 854/844 Main cable	29,57
902-207	Parking plug Hydr. cable	29,73
902-217	ISOBUS parking plug for break-away conn.	34,06
902-350	70 Series universal junction box, 8m	317,40
902-369	ABSC box Hardi BT-9 Sw.Box LH4000/LH5000	1634,83
902-844	Bracket kit TeeJet 8x4 RAM mount	136,23
902-954	Flow Meter MI140, 5" Slurry	2661,00
902-956	Flow Meter MI160, 6" Slurry	2661,00
902-980	Flow Meter 16D, JST con. with 1' hose	360,74
902-981	Flow Meter 16D, JST con. with 1' hose	335,99
902-984	Flow Meter 16D, Deutsch con. with 1'	367,28
902-986	Flow Meter 20D, 20-250 L/Min	306,19
902-990	Flow Meter 20D, Deutsch con. with 1.5'	417,44
903-102	Power Cable for LH 1000 Series	14,10
903-122	LH 1200 Tractor- & Sprayermonitor Kit	904,51
903-152	Clutches for 17mm hex. shaft	885,37
903-153	Clutch kit for 16mm square shaft	730,98
903-183	LH 4000 Sprayer Computer, DK/S/UK	1625,71
903-187	LH4000 D/CZ/HG	1555,77
903-269	TeeJet 834 EPC f/ATV kit: PR, SP	1071,01
903-282	Set 834-5, DirWir for TJ valves	1670,89
903-293	Set 834-0, Master, DirWir, Reg.valve	1518,85
903-309	ISOBUS Matrix 570VT kit incl. tractor	2297,49
903-316	ISOBUS Matrix 570VT kit (w/0.5m cable)	1798,13

\* Subject to RTK discount

\*\* Subject to REP discount

PART NO.	DESCRIPTION	EURO
903-318	ISOBUS Matrix 570VT kit incl. tractor	2184,00
903-319	ABSC box, Hardi HC2500 w/Scanbox ESC/EVC	1205,22
903-322	ABSC box, Müller Spray-Contr. S, 9 Sect.	1535,42
903-325	ABSC box, Müller Spraydos 7 Sect.	1535,42
903-326	ABSC box, Müller Spraydos 5 Sect.	1535,42
903-327	ABSC box, Müller Spraydos 9 Sect.	1535,42
903-330	ABSC box, Arag 180, 4 Sect., complete	1535,42
903-331	ABSC box, Arag 180, 5 Sect., complete	1535,42
903-333	ABSC box, Arag 300, 5 Sect., Cobo pwr	1535,42
903-335	ABSC box, Blanchard Agrotroxion 9 Sect.	1535,42
903-336	ABSC box, Arag manual controller 466	1095,15
903-338	ABSC box, Dubex Spray-Control S, 11S	1810,58
903-339	ABSC box, Hardi BT-9 LH4000/LH5000	1755,55
903-362	ISOBUS Matrix 570VT kit (w/3m cable)	1805,87
903-499-DK	LH 500 Traktormonitor kpl. DIN/ISO Vers.	893,88
903-505-DK	TJ Intellitram 500 Computer	953,33
903-505-F	LH Intellitram 500 computer, Fransk	953,33
903-505-S	LH Intellitram 500 computer, Svensk	953,33
903-505-UK	TJ Intellitram 500 Computer, English	953,33
903-602	Bracket kit TeeJet 8x4, simple	117,17
903-765	Cabling LH 765	101,15
903-771	71 Single-Sensor Monitor, no SW	266,81
903-771-001-D	71 Single-Sensor Monitor	241,29
903-771-001-F	71 Single-Sensor Monitor	241,29
903-771-001-NL	71 Single-Sensor Monitor	241,29
903-771-002-UK	71 Single-Sensor Monitor, RPM, -UK	246,57
903-771-018-UK	71 Single-Sensor Monitor	360,61
903-771-027-F	71 Single-Sensor Monitor, TankMatic	261,58
903-771-027-I	71 Single-Sensor Monitor, TankMatic	236,56
903-772	72 Multi-Sensor Monitor, no SW	382,84
903-772-012-D	72 Multi-Sensor Monitor, Slurry Monitor	354,87
903-773	73 Multi-Purpose Controller, no SW	482,60
903-773-005-H	73 Multi-Purpose Controller	482,60
903-773-005-NL	73 Multi-Purpose Controller	482,60
903-773-008-UK	73 Multi-Purpose Controller	440,83
903-773-026-D	73 Multi-Purpose Controller	482,60
903-773-026-I	73 Multi-Purpose Controller	482,60
903-773-026-SP	73 Multi-Purpose Controller	510,44
903-773-036	73 Multi-Purpose Controller, Speed RPM	482,61
903-775-005-I	73 Multi-Purpose Controller, panel	467,51
903-985	Flow Meter Alu. 10 mm	580,46
904-102	LH 1000 Tractor Monitor Kit, all incl.	594,50
904-107	LH 1000 Red/white Beta + 1 magnetring	653,81
904-151	Hopper level sensor, M30 green	216,53
904-168	70 Series conn. kit for machine cable	23,30
904-181	LH 5000 ver. 3, Bracket with 3 m cable	159,35
904-182	LH 5000/LH4000 Bracket without cable	84,83
904-189	LH 5000 Bracket with 5 m cable	178,34
904-220	Radar D-J (non UK)mounting bracket incl.	1644,04
904-252	Tractor junction box, ISO hitch, Cobo	696,84
904-300	844E, no Sections, Comm.	1568,07
904-301	844E, 5 Sections, Comm., Speed	1581,56
904-302	844E, 9 Sections, Comm., Speed	1739,16
904-303	844E, 7 Sections, Balance	1660,59
904-304	844E, 9 Sections, Balance	1727,07
904-305	844E, 7 Sections, Comm., Speed	1659,79
904-310	844E+ Basic, no Sections, Comm.	1862,65
904-311	844E+ Basic, 4 Sections, Comm., Speed	1904,87
904-312	844E+ Basic, 5 Sections, Comm.	2086,29
904-313	844E+ no Sections, Comm.	1862,65
904-314	844E+ 5 Sections, Comm.	2086,29
904-315	844E+ Basic, 6 Sections, Comm.	2103,55
904-320	844AB 4 Sections, Comm., Speed	1588,71
904-321	844AB 4 Sections, Reg., Comm., Speed	1271,05
904-322	844AB 6 Sections, Comm., Speed	1743,25
904-390	TeeJet 854, 9 Sections, Comm., Speed	1797,78
904-392	TeeJet 854, 7 Sections, Comm., Speed	1725,87
904-765-DK	LH 765 Grain loss monitor	984,55
904-855	Flow Meter MI100, 4" Slurry	2661,00
905-000	Sensor kit for grain loss monitor	805,04
90-50013	Kit, Cable tie, Bundle (15)	25,22
90-50155	Patch antenna with 4m cable	150,94
90-50230	Kit, 801 Flow Meter 1" 0.5m cable	468,17

PART NO.	DESCRIPTION	EURO
90-50232	Kit, 801 Flow Meter 1-1/4" 0.5m cable	468,17
90-50250	TeeJet 744E-5 kit, 100PSI/7Bar liquid,	845,01
905-119	Speed Sensor kit, 3 pol Binder, 6 magnet	121,61
905-122	LH 1200S Connection box, standard	105,81
905-152	Drill Shaft Control, 17mm hex.	468,41
905-159	LH 4000 Trailer mounting kit	618,33
905-164	Hardi EC Interface for LH 4000	676,10
905-165	Hardi interface for LH4000/LH5000	711,35
905-242	Printer for LH 5000 Ver. 4, 12v/110 mm	787,32
905-244	Printer for LH 500	787,32
905-245	Printer Alfapanel 3S.24 HS, +12V, RS232	851,84
905-510-D	TeeJet 500 Slurry, incl. manuals -D	1879,97
905-510-DK	TeeJet 500 Slurry, incl. manuals -DK	1879,97
905-510-E	TeeJet 500 Slurry, incl. manuals -ESP	1879,97
905-510-F	TeeJet 500 Slurry, incl. manuals -F	1879,97
905-510-UK	TeeJet 500 Slurry, incl. manuals -UK	1879,97
905-865	Multi cable for LH 865 with plug	100,74
905-985	Flow Meter insert 10D/16D/20D 0.5m cable	106,84
905-986	Flow Meter insert 16D/20D, 10m	233,52
906-012	Junction Box for LH 865	52,64
906-114	Interface DIN/ISO for TJ 1000/1200	240,91
906-117	Interface DIN/ISO for Holder	240,91
906-153	Clutches for ø20mm shaft, excl. wheels	1032,66
906-200	PTO Magnetring	28,24
906-300	Print for junction box, LH 5000 Ver. 2	103,00
906-865	Junction box for LH 865, Front	76,34
906-986	Flow Meter 20D, 10m	318,11
906-987	Flow Meter 10D, 10m cable	367,47
906-988	Flow Meter 20D with 0.5m cable and	134,51
906-989	Flow Meter 10D with 0.5m cable and	293,71
907-012	Straw walker Sensor, LH standard (1994)	217,95
907-164	Operation Box, Mixer Valve for Slurry	168,26
907-184	LH 5000 Multi Computer, GPS Version	2775,57
907-865-D	LH 865 Kapacitetsindikator inkl. Vejl.	1381,11
907-865-DK	LH 865 Kapacitetsindikator inkl. Vejl.	1381,11
907-865-S	LH 865 Kapacitetsindikator inkl. Vejl.	1381,11
907-980	Flow Meter 16D with 8m cable and	257,94
907-981	Flow Meter 16D with 1.5m cable and	326,62
907-985	Flow Meter 16D with 0.5m cable and	255,98
907-986	Flow Meter 16D with 10m cable	334,85
908-012	Straw Walker Sensor Kit (2 pcs)	436,74
908-122	Connection box w. switches for LH 1200S	169,93
908-986	Flow Meter 26D, 6m	384,10
908-988	Flow Meter 26D with 0.5m cable and	444,96
908-989	Flow Meter 26D, 10m	399,60
909-500	LH500C mounting kit	212,55
909-865	LH 865 Mounting Set	432,19
909-983	Sensor, 2 core w. 2p AMP SS conn., 5m	57,37
909-986	Flow Meter 40D, 50-1000 L/Min	509,37
90VM24.01	Flow Meter Pick Up, 10m cable	125,43
91-00014	FieldPilot 230 New System Kit	2906,60
91-00018	FieldPilot Matrix New System Kit	2906,60
91-00021	Kit, Fieldpilot System, MTZ	4030,79
91-00022	Kit, Articulated Gyro Module, Pro	881,60
910-164	Hardi EC Autodose for LH 4000	1043,86
910-214	LH 5000 Tractor Mounting Set	445,52
910-215	Install. Parts	44,14
910-219-D	Hydraulisk styring af gyllevogn incl. MS	1835,57
910-219-DK	Hydraulisk styring af Gyllevogn incl. MS	1835,57
910-219-F	Hydraulisk styring af Gyllevogn incl. MS	1835,57
910-219-S	Hydraulisk styring af gyllevogn incl. MS	1835,57
910-219-UK	Hydraulisk styring af Gyllevogn incl. MS	1835,57
91-02206	Kit, Platform John Deere 7000 Series	2464,26
91-02228	Kit, Platform CASE MX 210/230/255/285	2487,59
91-02239	Kit, Platform, JD9x20 Series	2453,93
91-02241	Kit, FP Basic Vehicle, Open Center w/PR	2430,33
91-02272	Kit, platform JD6420	2487,59
91-02277	FieldPilot basic vehicle kit, OC	2464,26
91-02283	KIT, PWM PLATFORM CASE MX	3008,43
91-02284	Vehicle kit - Newholland TM series	3008,43
91-02286	Kit, PWM PLATFORM CASE 71XX,72XX,89XX	2979,50
91-02294	Kit, PWM PLTFM JD 6x10,6x20,7x10,7x20 SF	3008,43
91-02300	Vehicle Kit, PWM, Fendt 820, COM3	2464,26

\* Subject to RTK discount  
 \*\* Subject to REP discount

PART NO.	DESCRIPTION	EURO
91-02302	Kit, PWM JD 7x20 LF	3008,43
91-02305	KIT, PWM, JD 9x20 4WD	4705,37
91-02338	Vehicle Kit (PWM) for tractor AGCO	3008,43
91-02339	Kit, Fieldpilot Vehicle	3018,80
91-02400	UniPilot kit, New System	4413,13
91-02402	UniPilot kit, New System w/o Pwr/CAN/	4300,09
91-02700	FP Kit, CASE MX W/Factory valve	3749,40
91-02701	FP Kit, AT-Ready JD8x10, 8x20, 8x30	3749,40
91-02702	FP Kit, AT-Ready JD8xxx R-Series	3749,40
91-02705	PLATFORM KIT Case STX/NH, 4WD SERIES	4630,99
910-282	LH500 seed drill kit 1 excl computer	384,45
910-300	TJ500 Slurry mounting kit	1333,73
910-303	TJ500 Slurry Instal. Kit, incl. Speed &	1029,12
910-402-F	TankMatic kit incl. sensors, cables	1117,06
910-402-UK	TankMatic kit incl. sensors, cables	1117,06
910-411	FieldPilot CL220 kit, w/o CL220, OC	5706,36
910-510	FieldPilot Matrix Pro. kit	5706,36
910-512	FieldPilot CL230BP kit, CC, LS	5706,36
910-514	Vehicle Kit, PWM, Fendt 936	3879,82
912-152	LH 1600 Add. Mountingkit	203,17
912-183	LH 4000 Sprayer computer UK/E/P	1625,71
913-152	LH 1600 Bracket Kit	26,67
913-513	80 Series bracket kit with rod	251,82
914-183	LH 4000 Sprayer Computer D/CZ/PL	1625,71
915-122	LH 1200S Sprayer Monitor no mountingkit	714,67
915-122-D	LH 1200S Sprøjtemonitor u/monteringsæt	714,67
915-122-DK	LH 1200S Sprøjtemonitor u/monteringsæt	714,67
915-122-F	LH 1200S Sprøjtemonitor u/monteringsæt	714,67
915-122-S	LH 1200S Sprøjtemonitor u/monteringsæt	714,67
915-122-UK	LH 1200S Sprayermonitor no mountingkit	714,67
915-183	LH 4000 Computer Head UK/D/F	1625,71
916-123-D	LH1200S Mounting set with Switches	342,91
916-123-DK	LH1200S Mounting set with Switches	342,91
916-123-F	LH1200S Mounting set with Switches	342,91
916-123-S	LH1200S Mounting set with Switches	342,91
916-123-UK	LH1200S Mounting set with Switches	342,91
916-124-F	TeeJet 1200 Slurry Monitor -F	609,68
916-124-UK	TeeJet 1200 Slurry Monitor -UK	609,68
917-124-F	TeeJet 1200 Slurry Monitor Kit -F	1107,43
917-124-UK	TeeJet 1200 Slurry Monitor Kit -UK	1107,43
917-181	LH 5000 Tractor computer Version 4	2167,74
918-123	LH 1200S Fitting kit, excl. Switches	277,25
918-123-D	LH 1200S Fitting kit, excl. Switches	277,25
918-123-DK	LH 1200S Fitting kit, excl. Switches	277,25
918-123-F	LH 1200S Fitting kit, excl. Switches	277,25
918-982	Mini Sensor, 2 core, 5 meter	45,52
918-986	Flow 26D Insert Complete, 6m	256,52
918-988	Flow Meter insert 26D, 0.5m cable	168,36
918-989	Flow insert D26, 10m	276,26
919-986	Flow 40D insert complete. 6m cable	256,52
919-988	Flow Meter insert 40D 0.5m cable	194,03
921-180	LH 5000 Universal Drill Kit	303,89
924-327	BT-9 Connection box w/5.5 m cable	434,46
925-327	BT-9 Operating Box (4 Sec.), Kit Hardi	1272,85
926-982	Hjulfølørsæt, 2-ledet 5m, 8 magneter	107,40
926-986	Flow 16Dx0,75" BSPT conn. kit, female	89,66
927-021	Sieve sensor 1648 mm stainless steel	370,75
927-986	Flow 26Dx1,5?? BSPT conn. kit	119,32
928-020	Sieve Sensor steel 1648mm with cable	381,81
929-127	Connecting Cable LH 5000/LH 5000D (v.3)	198,64
929-986	Flow 40Dx2" BSPT conn. kit, male	134,24
92VM57.00	Velleman sensor for POLMAC Flow Meters	198,48
930-600	Trailer Plug & Socket, Kit	35,61
930-775	Magnet Set (2 pcs.)	7,37
930-870	Flow 10D/16D/20D paddle service kit	39,30
930-871	Flow 26D paddle service kit	68,98
930-872	Flow 40D paddle service kit	109,67
930-982	Sensor kit complete, 2-core, 5 Meter	53,35
930-983	Sensor Kit, 3-core, 5 meter	81,59
930-984	Sensor 3 core bipolar prop shaft, Kit	85,27
930-986	Inline-kit Hardi-Matic x 20D	148,98
931-982	Sensor Kit, 2-core, 10 meter	62,30
931-983	Sensor Kit, 3-core, 10 meter	81,59

PART NO.	DESCRIPTION	EURO
931-985	Sensor kit, 2 wire, 10m w/2P AMP SS	97,90
931-986	Inline-kit Hardi EC x 20D	127,70
932-983	Sensor 3-core RPM with PTO magnet ring	101,60
932-986	Flow 20Dx1" Hose Connection Kit	46,22
933-183	LH 4000 Spray Computer F/NL/FL	1625,71
933-983	Inductive Sensor kit	97,90
933-986	Flow 20Dx1" BSPT conn. kit, male	96,34
933-987	Flow 20D to TeeJet #50 flange conn., kit	96,70
933-988	Adaptor 20D Flow Meter to #50 flange	51,07
933-989	Adaptor 20D to 1" hose barb	21,91
933-990	Adaptor 20D to 3/4" hose barb	49,65
933-991	Flow 20D, 1,25?? hose conn.	43,27
933-992	Flow 20D, 1,5?? hose conn.	26,96
934-000	Flow 26D, 1,25?? hose conn.	67,04
934-001	Flow 26D, 1,5?? hose conn.	90,51
934-002	Adaptor 26D Flow Meter to #50 flange	54,64
934-982	Sensorkit 2-core w/10 m cable, 6 magnets	68,98
941-986	Flow 20Dx1.25" Hose Connection Kit	43,70
941-987	Flow 10D, 0,5?? hose conn.	48,25
941-988	Flow 16Dx1" Hose Connection Kit	82,29
941-989	Flow 16D, 0,75?? hose conn.	37,02
941-990	Flow 16D, 1?? hose conn.	46,10
941-991	Flow 16D to TeeJet #50 flange conn.	47,52
942-988	Flow 16Dx0,75 BSPT connection kit,	82,29
942-989	Flow Meter 10Dx3/4 BSPT conn. kit	86,84
943-986	Flow 20Dx0,75" Hose Connection Kit	87,55
943-988	Flow 16Dx0,75" Hose Connection Kit	78,60
944-986	Flow 20Dx1.5" Hose Connection Kit	82,29
946-986	Flow 26Dx1.25" Hose Connection Kit	90,37
947-986	Flow 26Dx1.5" Hose Connection Kit	86,70
948-986	Flow 40Dx2?? Hose Connection Kit	97,05
949-986	Flow 20Dx1" BSPT conn. kit, female	97,05
950-915	Adaptor 10D to 3/4" male BSPT	59,16
950-916	Adaptor 10D to 3/4" female BSPT	32,59
950-983	Adaptor 20D to 3/4" male BSPT	39,01
950-986	Adaptor 16D to 3/4" female BSPT	45,19
950-988	Adaptor 16D to 3/4" male BSPT	41,75
951-986	Adaptor 20D to 1" female BSPT	48,61
951-988	Adaptor 16D to 3/4" hose barb	39,71
952-986	Adaptor 20D to 1" male BSPT	48,61
956-986	Adaptor 20D to 1-1/4" hose barb	24,75
957-986	Adaptor 20D to 1 1/2" hose barb	41,75
958-986	Adaptor 26D to 1-1/2" male BSPT	86,81
95ET03	TeeJet AIRMATIC - AirJet controller	2632,90
961-986	Adaptor 40D to 2" male BSPT	67,10
962-986	Adaptor 40D to 2" hose barb	49,29
96ET05	Connector kit AirMatic	141,31
96ET10	Proximity switch without conn., 8m	58,86
96ET10-4	Speed Sensor with JST, 4m	66,21
96ET10-8	Speed Sensor with JST, 8m	69,54
96ET10-8D	Speed Sensor with Deutsch Con., 8m	67,18
96ET10S-8	Speed Sensor w/AMP Superseal, 8m	74,51
96ET11-0.5D	Flow Meter Pick Up, 0.5m w/Deutsch	131,65
96ET11-1.5	Flow Meter Pick Up, 1.5m w/JST, Polmac	131,50
96ET11-4	Flow Meter Pick Up, 4m w/JST, Polmac	125,25
96ET11-8	Flow Meter Pick Up, 8m w/JST, Polmac	125,25
96ET14	Battery cable, Battery <=> Cobo, 4m	45,61
96ET15-10	Main Cable, Console <=> Junction Box	161,48
96ET15-12	Main Cable, Console <=> Junction Box	193,01
96ET15-15	Main Cable, Console <=> Junction Box	203,26
96ET15-5	Main Cable, Console <=> Junction Box	144,25
96ET15-8	Main Cable, Console <=> Junction Box	158,56
96ET16-10	Power Cable, Cobo <=> Junction Box	103,41
96ET16-12	Power Cable, Cobo <=> Junction Box	155,81
96ET16-5	Power Cable, Cobo <=> Junction Box	69,54
96ET17-3	Communication Cable/Console <=> Sub-D	67,06
96ET23-SJ	Junction Box 844E, JST conn. 5 Sections	287,74
96ET25-8	Cable JST<=>JST, 8m	39,66
96ET26-1	Hosetail set for 1' Polmac Flow Meters	15,84
96ET26-3	Hosetail set for 1' Polmac flowmeters	14,20
96SP01-3P	Sparepart JST Connector 3P	3,29
96SP01-5P	Spare part JST connector 5p	4,70
96SP03	Spare part connector kit 28p Souriau	51,71

\* Subject to RTK discount

\*\* Subject to REP discount

PART NO.	DESCRIPTION	EURO
96SP03_P	Spare part connector kit 28p Souriau	76,96
97ET27	Junction Box TrackMatic	348,41
97ET32_S0	TeeJet 834, no Sections, no Master	1019,17
97ET32_S4	TeeJet 834, 4 sections	1067,66
97ET32_S5	TeeJet 834, 5 sections	1024,64
97ET32_S5_RP	TeeJet 834, 5 sect., master, pump reg.	1088,89
97ET55_S3_H15_10_EPC	TeeJet 754, 3sect. Reg. 10bar EPC	616,03
97ET64-5	Main Cable for 13 sections, 5m	154,97
97SS01-0.5	Proximity switch w/Deutsch, 0.5m	138,94
98-05137	User guide, FieldPilot 230 -US	11,23
98-05239	Manual, Matrix PRO, UK	22,47
98-50139	USB stick 2.0G TeeJet Technologies	27,52
98-60001	Matrix 570G/840G Language Kit, -D	43,15
98-60002	Matrix 570G/840G Language Kit, -DK	43,15
98-60004	Matrix 570G/840G Language Kit, -F	43,15
98-60005	Matrix 570G/840G Language Kit, -SF	43,15
98-60006	Matrix 570G/840G Language Kit, -HU	43,15
98-60007	Matrix 570G/840G Language Kit, -NL	43,15
98-60008	Matrix 570G/840G Language Kit, -PL	43,15
98-60009	Matrix 570G/840G Language Kit, -PT	43,15
98-60010	Matrix 570G/840G Language Kit, -RU	43,15
98-60026	Matrix 570G/840G Language kit, -S	43,15
98-60027	Matrix 570G/840G Language Kit, -I	43,15
987-800	Flow 20D body	98,62
987-801	Flow Meter 10D body	104,14
987-816	Flow 16D body	111,24
987-826	Flow 26D body	157,22
98ET03-1.5	Cable JST<=>DIN for PSENS, 1.5m	24,22
98ET03-3	Cable JST<=>DIN for PSENS, 3m	25,31
98ET05_S13-4	Extension for Main Cable, 4m	213,94
98ET10	Printer Comm. Cable Alfapanel 3	67,62
98ET11-1.5	Cable DIN<=>JST for valves, 1.5m	19,97
98ET38_S-1.5	Power supply Cable for consoles, 1.5m	41,90
98ET42	Direct wiring, 8m, 5x 460 valves	364,18
98ET42_FL	Direct wiring, 8m, 5x460 valves	364,18
98ET42_FL_PR	Direct wiring, 8m, 5x 460 valves, Flow,	385,38
990-040	TeeJet 744E, 433EC kit, w/o fittings	1293,01
990-041	TeeJet 744E, 435EC kit, w/o fittings	1506,73
990-070-D	TeeJet 71 Speed/area/distance -D	425,47
990-070-F	TeeJet 71 Speed/area/distance -F	425,47
990-070-UK	TeeJet 71 Speed/area/distance -UK	425,47
990-071-F	TeeJet 71 Speed/area/distance GPS	829,25
990-072-UK	TeeJet 71 RPM -UK	420,36
990-073-D	TeeJet 71 Working time/RPM -D	412,11
990-075-F	TeeJet 71 Filling Flow Meter, 20D	467,82
990-075-UK	TeeJet 71 Filling Flow Meter, 20D	467,82
990-076-UK	TeeJet 72 Pressure/RPM -UK	780,64
990-077-D	TeeJet 73 Sprayer regulation Pres.	1031,80
990-077-NL	TeeJet 73 Sprayer regulation Pres.	1031,80
990-077-PL	TeeJet 73 Sprayer regulation Pres.	1031,80
990-077-SK	TeeJet 73 Sprayer regulation Pres.	1031,80
990-077-UA	TeeJet 73 Sprayer regulation Pres.	1031,80
990-077-UK	TeeJet 73 Sprayer regulation Pres.	1031,80
990-080-P	TeeJet 71 Flow Meter, 16D -P	621,86
990-080-UK	TeeJet 71 Flow Meter, 16D -UK	587,94
990-082-UK	TeeJet 71 Speed/area/distance	477,93
990-095-UK	TeeJet 73 Sprayer regulation Pres.	803,08
99-01020*	RTK CORS activation code f/RX-600RTK	3290,97
99-01030*	GLONASS Activation Code f. RX600 RTK -EU	2190,31
990-765-D	LH 765 Spildindikator komplet sæt inkl.	1788,90
990-765-DK	LH 765 Spildindikator komplet sæt inkl.	1788,90
990-765-UK	TJ 765 grain loss monitor	1788,90
990-865-D	TJ 865 Grain loss Monitor, Kit	2186,31
990-865-DK	LH 865 Kapacitetsindikator komplet sæt	2186,31
990-865-F	LH 865 Kapacitetsindikator komplet sæt	2186,31
990-865-S	LH 865 Kapacitetsindikator komplet sæt	2186,31
990-865-UK	TJ 865 Grain loss Monitor, Kit	2186,31
990-888	Berthoud ABC kit for DP-Tronic, factory	1054,11
990-889	Berthoud ABC kit for DP-Tronic, factory	1476,77
990-906	BoomPilot Optima SwitchBox kit incl.	2835,35
990-907	BoomPilot Optima SwitchBox kit	1400,38
990-920	FieldPilot Matrix New System Kit	2906,60

PART NO.	DESCRIPTION	EURO
991-181	LH 5000 Multi Computer Kit	2590,97
99ET017-6	Speed sensor w/C-connector, 6m	101,19
99ET058_J	Junction Box 844E, 2x JST conn. 9 Sect.	493,34
99ET064-8	Tankmatic sensor cable, DIN<=>JST, 8m	52,98
BT3.0LI.27A51	Lithium battery PCB 3V (backup)	30,28
COA_UTG20AC	Souriau cable clamp w/strain relief	12,74
COA_UTG20PG	Souriau cable clamp w/strain relief	33,71
COA_UTG620DCG	Dustcap for main cable, 28p	32,74
COA_UTP12DCG	Dustcap for chassis receptacles	22,35
COA_UTP20DCG	Dustcap for chassis receptacles shell	15,84
COC_SCM11D70	Gold flash socket contact, 0.80 - 1.50	0,70
COC_SM16M11D70	Gold flash pin contact, 0.80 - 1.50mm2,	0,70
COC_SVH21TP11	Socket contact for JST VHR connectors	0,35
COC_SXH001T	Small socket contact for JST XHP con.	0,12
COC_UTG6104SN	Souriau 4p cable plug, sockets	20,96
COC_UTG6128SN	Souriau 8p cable plug, sockets	23,18
COC_UTG62028PN	Souriau 28p cable plug, pins	26,31
COC_UTG62028SN	Metalok Circular Trio Mate connector 28P	24,09
COC_VHR3N	Connector JST 3p VH	0,48
COC_VHR5N	5P connector	0,51
COC003DIF003	Conn. DIN valve IP65 incl. M3x35 screw	5,88
COS_UTG0128S	Metalok circular Trio mate receptacle	16,39
COS_UTG01412P	Souriau receptacle 12p chassis, pins	14,84
COS_UTG02028P	Metalok Circular Trio Mate receptacle	13,13
COS_UTG02028S	Metalok Circular Trio Mate receptacle	14,43
FM1.00RCTN000	Flow Meter 1" RILSAN, no sensor	394,99
FM2.00RBTN000	Flow Meter, 2", RILSAN, no sensor	392,13
HO/_/_/A1B1	Cable gland PG9, black, d4-8mm	2,16
PSENS07.00	Pressure sensor 0-60 bar (4-20mA)	180,37
PSENS09	Pressure sensor 0-2.5 bar (4-20mA) for	180,37
PSENS11	Pressure Sensor TankMatic, 0-0.25bar	528,22
RAD02	Radar D-J 6m cable mount. equipm. incl.	1248,84
SET99ET001_STA	Set TrackMatic, Jbox, Stand alone	1564,52
SET99ET005	TeeJet Field simulator Set	783,54
SET99KR001	Set 844E-5, Jbox, Pol 1" Ceram. 10bar	3011,03
001-250**	Hourly repair rate	90,00
001-251**	Repair category 1	90,00
001-252**	Repair category 2	180,00
001-253**	Repair category 3	270,00
001-254**	Repair category 4	360,00
001-255**	Repair category 5	448,75
001-256**	Same-Day-Repair service fee	120,00
001-257**	GPS receiver firmware update	28,07
001-259**	Repair category 6	560,00
001-261*	Virtual Wrench Type A, Basic 12 months	423,75
001-264*	Virtual Wrench, additional consoles	148,66
001-265**	SCM-TGM-ATM module software update	25,00

\* Subject to RTK discount

\*\* Subject to REP discount

# REPAIR & SERVICE

## Standard Repair Prices

PART NUMBER	TYPE	DESCRIPTION	LIST PRICE EURO
001-251	Repair Category 1	Diagnostic fee –all products. Also used for all product platforms for: • Simple Repair (fuse, connector or minor defect) • Software Update (if required)	90,00
001-252	Repair Category 2	Repair of 'Low Cost' Consoles.....	180,00
001-253	Repair Category 3	Repair of 'Mid-range' Consoles.....	270,00
001-254	Repair Category 4	Repair of 'High End' Consoles.....	360,00
001-255	Repair Category 5	Repair of 'Advanced-1' Electronics.....	448,75
001-259	Repair Category 6	Repair of 'Advanced-2' Electronics.....	560,00
001-256	Same-Day-Repair	Same-Day-Repair service; Service fee ...	120,00
001-250	Hourly Repair Rate	Standard hourly repair rate.....	90,00

All repair categories carry a 'REP'-discount. Repair charges are invoiced with standard payment terms. Prices and specifications may be subject to change without prior notification.

## We Repair The Following Products

PRODUCT PLATFORM	REPAIR CATEGORY	PRODUCT PLATFORM	REPAIR CATEGORY
TJ 71, 72, 73	2	TJ 500, LH 500, 500 C.....	4
LH 1000	2	BoomPilot Box (ABSC).....	4
LH 1200, 1200 S, 1200 Slurry	2	LH 5000, 5000 GPS.....	5
LH 1600, 1600 M	2	LH 565, 665, 665+.....	5
TJ 814, 834, 844, 854, 860	3	LH 965.....	5
TJ 74, TankMatic	3	BT9 Switch box.....	5
LH 765, 865	3	Matrix 570G.....	5
TJ SprayMatic+	3	Matrix 840G.....	6
TJ AirMatic	3	GPS-Receiver: RX350, RX370....	6
TJ Hydraulic Switch box	3	Matrix 570 VT (ISOBUS).....	6
BoomPilot® Console	3		
LH 4000	4	IC18, IC24, IC34.....	OEM
LH 6000, LH 600 VT (ISOBUS)	4	TJ85 Series.....	OEM
CenterLine® 220, 230, 250	4	GPS-Receiver: RX4xx or RX5xx ...	Contact Support
CenterLine Classic	4	SmartPad II, Legacy, Swath XL ...	Contact Support

## Special Items

Items not identified on the product repair list will be repaired using the standard hourly repair rate plus parts, if the item is repairable. Please contact TeeJet Technologies Technical Support department for more details.

## Returning A Product For Repair

All items returned for repair from end users or non-TeeJet Technologies dealers must be pre-approved by a TeeJet Technology dealer. Please contact your regional TeeJet Technologies office or TeeJet Technologies Technical Support department if you need assistance finding a dealer.

**Remember to include a brief written description on the reason for your return!**

An 'RMA' form can be requested via support.aabybro@teejet.com

## Cleaning Requirements

Products returned to TeeJet Technologies must be thoroughly cleaned and free of all chemical contamination. Items which are not properly cleaned will be returned to the owner at their expense.

## OEM Products

Repair of OEM products is normally handled by the OEM customer. Please contact your regional TeeJet Technologies office or TeeJet Technologies Technical Support department for assistance.

## Diagnostic And 'No Defect' Check Out Fees

- Items returned for repair which are diagnosed with 'No Defect' will be charged a standard No-Defect diagnostic fee.
- A diagnostic fee will also be applied to items which are diagnosed 'Non Repairable'. These items will be returned or scrapped according to the customer's request.

## Same-Day-Repair Service Charges

Customers requesting 'Same-Day-Repair' service will be charged an additional Same-Day-Repair service fee.

**Please note:** Same-Day-Repair service may not be available on all products. Please contact TeeJet Technologies before returning the item.

## Unauthorized Modifications And Repairs

Unauthorized modifications on any product manufactured or distributed by TeeJet Technologies will automatically void the factory warranty. Standard 'Out-of-Warranty' charges will be added to update the product(s) to 'Warranty Status'.

## Repaired Items Warranty Period

Items returned for repair to TeeJet Technologies will be provided a 90-day warranty period from the date of repair.

## Service Replacement Consoles

TeeJet Technologies dealers are responsible for stocking service replacement consoles. If a dealer is temporarily out of service inventory, TeeJet Technologies has a limited inventory of re-manufactured consoles to be used in special cases. Please contact TeeJet Technologies Technical Support department for specific product availability. The service replacement unit will be invoiced with the standard list price for the product. When the defect unit is returned to us, along with the order number following the replacement unit, the invoice will be changed to the actual repair price plus a Same-Day-Repair service fee.

## Online Support

Tel.: +45 96 96 25 05 (Northern Europe)  
Tel.: +33 2 38 69 70 72 (Southern Europe)  
support.aabybro@teejet.com

The number above is the main support number. You can also contact us by e-mail. The team covering Europe receives e-mails in Danish, English and German. Written replies are provided in Danish or English. For Southern Europe, e-mails are received and replied to in French and English.







## **(1) APPLICATION AND VALIDITY**

(1.1) Present sales and delivery conditions apply for any quotation, order, and delivery unless deviated from in a signed agreement.

(1.2) Special or general conditions in sales material, orders, or purchase conditions, etc. made by the buyer are not considered as exceptions unless accepted by the seller in writing.

## **(2) PRICES AND SHIPMENT**

(2.1) The seller's prices stated in the current price list of products and spare parts are without the rate of VAT in force at the time in question, extra expenses and packaging. The seller reserves to himself the right to change the prices (without notice/at 4 weeks notice). Confirmed orders will, however, be delivered at the price in force at the date of the order confirmation. Mounting and installation are not included in the price. Please ask for separate quotation.

(2.2) Unless otherwise agreed in writing, terms of shipment are ex works LH Technologies Aps, Moelhavevej 2, 109, DK-9440 Aabybro, acc. to Incoterms 1990. Damaged goods must immediately be complained to the responsible forwarding agent (carrier, etc.).

(2.3) Any transport costs for products for repair or for service exchange (from sender to LH Technologies and from LH Technologies to customer) are on the buyer's account. On return of products bought by mistake, the seller submit a credit note for the invoice amount less 20%.

## **(3) PLACING OF ORDERS AND DELIVERY TIME**

(3.1) The buyer places the order in writing, preferably by telefax or email. The order must contain the LH part numbers. (as stated in the price list), quantity and requested time of delivery.

(3.2) Standard articles usually are stock goods. The time of delivery for temporarily sold out goods or for special products will be stated in the seller's quotation/confirmation of order. The agreed delivery time is not binding for the seller, if the buyer does not keep the agreed payment terms as to payment in advance, opening of L/C, or producing a banker's guarantee.

(3.3) Delays caused by the seller and not subject to force majeure entitle the buyer to contact the seller in writing and demand delivery. The buyer is in such case entitled to fix a final delivery time within minimum 4 weeks. If the seller does not keep the delivery time fixed by the buyer, the buyer is entitled to cancel the agreement.

(3.4) The buyer cannot put forward any other claim for consequential losses or damages, etc. in connection with the delay.

## **(4) SPECIAL-PURPOSE OR PRIVATE LABEL PRODUCTS: SPARE PARTS AND POSSIBLE SURPLUS STOCK**

(4.1) When placing orders for special-purpose or private label products the buyer is under an obligation also to order spare parts of special components if he wants original colour, design, construction, etc. for service and repair purposes. If the buyer does not make such an order the seller is not under the obligation to supply exchange products or components with original colours, etc. for warranty repairs, repairs after the warranty period, etc. The seller's service department will assist in calculating the demand on above quantities.

(4.2) If the buyer stops placing orders for a special-purpose or private label product or if the buyer does not buy the surplus stock of special-purpose or private label products from the seller within a reasonable time the seller is entitled to demand payment of the surplus stock from the buyer.

(4.3) The seller's prices stated for special-purpose or private label products does not include expenses for layout and working drawings of special designs. Costs for preparation of manuals (layout, working drawing, etc.) are not included. The price includes design with max. 3 colours. (More colours against additional price). Also the price includes packaging of the product in the seller's standard packaging. (Other packaging against additional price).

## **(5) PAYMENT AND RETENTION OF TITLE**

(5.1) Unless otherwise specially agreed the terms of payment is: 30 days, net.

(5.2) Delays do not entitle the buyer to withhold payment, just as payment cannot be withheld due to the buyer's counterclaims, if any.

(5.3) In case the buyer does not pay in due time the seller is entitled to demand interest according to the rate stated in the seller's quotation/order confirmation / invoice as per commenced month from the due date of payment till the amount is duly settled. In case no rate of interest has been stated, 1½% per month will be claimed. Unless otherwise agreed payment must take place as a bank transfer to the seller's account for the buyer's expenses.

(5.4) The seller reserves the right of ownership to any delivery, also if not specially claimed, until the entire amount, including payment of interests, if any, has been duly settled.

## **(6) COMPLAINTS, WARRANTY AND DEFICIENCIES**

(6.1) On receipt the buyer is obliged to examine that the goods are in good condition. The buyer must inform the seller of any deficiency not later than 48 hours after the receipt of the goods.

(6.2) On the condition the agreed terms of payment are fulfilled the seller grants 12 months warranty from the date the user puts the product into service, however, max 13 months from the date of delivery to the buyer. The warranty includes errors and deficiencies due to manufacturing faults. Faulty products must be returned to the seller together with the name and the address of the user, name of the buyer, date of purchase, serial No., and description of the error. The seller will then determine if the product will be repaired according to guarantee terms.

(6.3) The seller's guarantee and the buyer's right to have a defect repaired will be observed by a replacement, returning and credit of the goods in question, or by granting the buyer a price reduction. It rests with the seller what solution to make use of.

(6.4) A justified warranty claim sent to the seller within 60 days from the delivery will often be handled by forwarding a replacement product, however, the seller is not obliged to. During the remaining warranty period a warranty claim will often be settled by sending a renovated product or by repairing the faulty product forwarded to the seller. In warranty cases the seller pays for standard transport costs to and from the seller. In case the buyer wants special transportation services, say courier, express, etc., the buyer himself must pay the extra costs. A warranty repair made by the seller includes materials and wages, but excludes external repairs and wages, unless specially agreed in advance with the seller's service manager (in writing).

(6.5) The seller's responsibility for faults and defects is always and in any case limited to repair, exchange, returning and credit or a price reduction.

(6.6) The seller's responsibility for faults and defects does not include the consequences of natural wear and tear, insufficient maintenance, faulty operation, repairs not made by the seller or any other circumstance for which the buyer is responsible or bears the risk.

## **(7) PRODUCT USAGE**

(7.1) Any use of the product is at the sole risk of the buyer. The buyer is therefore not entitled to any form for compensation caused by, for example, any of the following: Disturbance to/from any electronic services or products that do not confirm to the standards for CE marking.

Missing or poor signal coverage or a succession hereof from external transmitters/receivers, used by the buyer.

Functional faults, which apply to or from a PC-program or PC-equipment, not delivered by the seller.

Faults that may arise from the buyers negligence to react to warnings and fault messages from the product, or which can be traced to negligence and/or absent constant control of the work carried out in comparison to the planned job.

(7.2) When implementing any new equipment the buyer must take great care and pay attention. Any doubts as to correct operation/use should result in contacting the seller's service department.

## **(8) VIOLATION OF PATENT OR TRADE MARK**

(8.1) The seller disclaims the responsibility for any violation of third party's immaterial rights on products marketed, distributed, and sold by the buyer under his name and trade mark, including violation of trade marks, etc, which the product or its application might give reason to, whether the product is used isolated or in configuration with other products. This also applies for products marketed in the seller's name or trademark where the product is part of a configuration or the like with other products.

## **(9) PRODUCT LIABILITY**

(9.1) The seller is not liable for damage on real and personal property that occur while the goods are in the buyer's possession. Besides the seller is only liable for damage on real and personal property in case it can be proven that the damage is due to neglect caused by the seller or by person for whom he is responsible.

(9.2) Nor is the seller liable for damage on products manufactured by the buyer or on products on which these are part.

(9.3) The seller is not liable for any loss of profits or any other indirect losses. Besides the seller's liability cannot exceed € 1.500.000 just as the seller is only liable for 1 year from the date the product was received by the buyer. The stated amount is the seller's maximum product liability towards the buyer within 1 year.

(9.4) To the extend the seller might be held liable for product liability towards third person the buyer shall indemnify the seller to the same extend as the seller's liability is limited according to above conditions.

(9.5) In cases where both buyer and seller are liable as manufacturers the buyer shall bear the final liability, according to the law on product liability, § 11, sub-article 2.

(9.6) If a third party claims compensation for product liability towards the buyer the buyer must immediately inform the seller accordingly in writing.

## **(10) FORCE MAJEURE**

(10.1) The following conditions will give the seller freedom from responsibility when they occur after the agreement has been entered and thus obstruct or postpone the fulfilment of the agreement:

(10.1.1) War and mobilisation, revolts and riots, catastrophes of nature, strikes and lockouts, shortage of goods and shortage and delays of supplies from sub-suppliers, fire, missing transportation opportunities, currency restrictions, import/export restrictions and other circumstances beyond the seller's control.

(10.2) In these cases the seller is entitled to cancel the order completely or partly or to execute the order when the fulfilment obstruction has come to an end.

## **11. LAW AND JURISDICTION**

(11.1) Any dispute between buyer and seller in connection with the agreement, including the interpretation and the extend of present sales and delivery conditions must be settled by Danish Court after the seller's choice, either at the Law in Aalborg or by arbitration in accordance with the rules laid down in the "Copenhagen Arbitration".

(11.2) Besides the seller is entitled to bring an action at the court in the jurisdiction where the buyer's business is situated.

(11.3) Regarding product liability buyer and seller are mutually obliged to let him sue at the court that deals with claims of damages that a third party wants to have settled by the court.



**Aabybro Facility**

Mølhavevej 2  
DK 9440 Aabybro  
Denmark

**[www.TeeJet.com](http://www.TeeJet.com)**